



Brio

# AQUUS

1000 GPD

Tankless 2:1 RO Filtration  
System with Smart Faucet

Setup Manual

Model No.: TROE1000COL

# Table of Contents

<b>Safety Information</b> .....	<b>3</b>
<b>Intended Use</b> .....	<b>4</b>
<b>Package Contents</b> .....	<b>4</b>
<b>Product Features</b> .....	<b>5</b>
Installation Overview .....	5
Operational Specifications .....	5
Technical Specifications .....	6
TDS Reduction Rates .....	6
<b>Installation</b> .....	<b>6</b>
Materials Needed .....	6
Installation Overview .....	6
Connect to the Cold Water Supply .....	7
Connect the RO Wastewater Tube .....	8
Install the Smart Faucet .....	9
Complete the Installation .....	10
<b>Operation</b> .....	<b>10</b>
Start Up the Filtration System .....	10
Shutting Down the Water Filtration System .....	11
<b>Care and Maintenance</b> .....	<b>11</b>
Filter Replacement Schedule .....	11
Replace Filters .....	11
Flushing the Filters .....	11
<b>Troubleshooting</b> .....	<b>12</b>
<b>Warranty</b> .....	<b>13</b>

# Safety Information

**WARNING:** To reduce risk of injury and property damage, you must read this entire guide before assembling, installing, and operating this filtration system.

- This RO water filtration system is not intended for use by persons (including children) with reduced physical, sensory, or mental capabilities, or lack of experience and knowledge, unless they have been given supervision or instruction concerning use of the appliance by a person responsible for their safety.
- This RO water filtration system requires a dedicated 3-prong outlet. If you do not have one, consult a professional electrician to have one installed.
- DO NOT use system if power cord is damaged. Contact customer service immediately for a replacement. When unplugging power cord ALWAYS grasp plug firmly to remove. DO NOT pull on power cord itself as this may cause damage or electrical shock.
- DO NOT expose filtration system to direct sunlight as this may cause damage.
- DO NOT store or expose system to temperatures lower than 32°F (0°C).
- DO NOT install filtration system near heat sources, open flames, or combustible substances.
- DO NOT place magnetic devices near system as damage could occur.
- DO NOT place heavy objects on top of system.
- DO NOT allow children near system without adult supervision.

# Intended Use

This appliance is intended to be used in household and similar applications such as:

- Staff kitchen areas in shops, offices, and other working environments
- Farm houses
- Hotels, motels, and other residential-type environments
- Bed-and-breakfast environments
- Catering and similar non-retail applications

# Package Contents

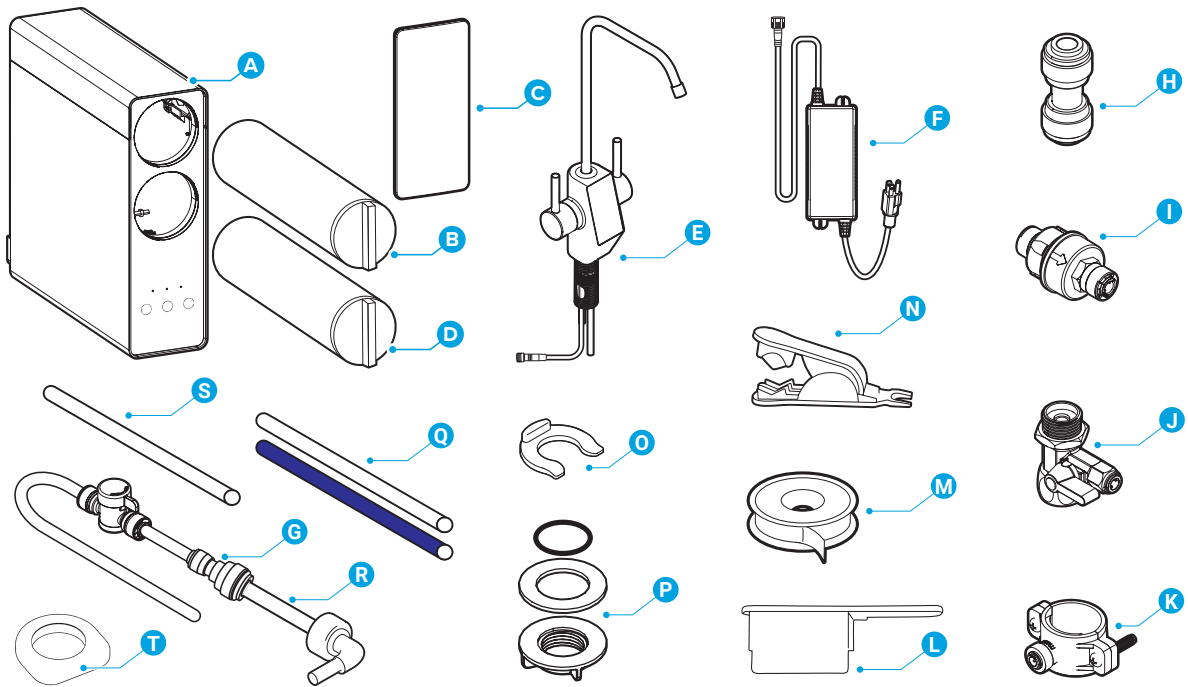

Part	Description	Quantity
A	RO filtration unit	1
B	RO filter	1
C	Filter compartment cover	1
D	PCB filter	1
E	Smart faucet	1
F	Power cord with adapter	1
G	1/4"-3/8" Reducing union	1
H	1/4" Quick connect	2
I	Pressure reduction valve	1
J	Feedwater adapter	1

Part	Description	Quantity
K	Drain saddle	1
L	Filter release tool	1
M	Plumber's tape	1
N	Tube cutter with release tool	1
O	Locking clip	6
P	Faucet mounting hardware	3
Q	Smart faucet tubing	2
R	Shut-off valve tube	1
S	Wastewater tube	1
T	Optional faucet base	1

# Product Features

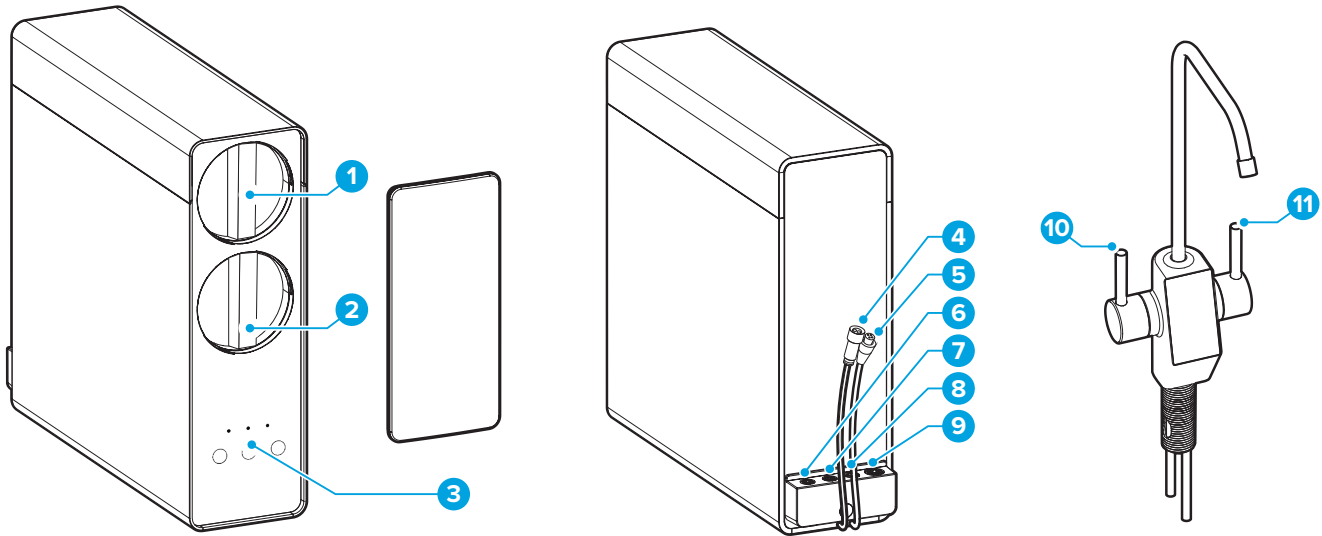

Part	Description
1	RO filter compartment
2	PCB filter compartment
3	Indicator panel
4	System power cord connection
5	Smart faucet power cord connection
6	Wastewater port

Part	Description
7	Purified water port
8	Filtered water port
9	Inlet water port
10	Filtered water handle
11	Purified water handle

## Indicator Panel Description

No.	Description
1	Power indicator light
2	Filter indicator lights
3	Power supply button
4	Filter reset button
5	Filter flush button

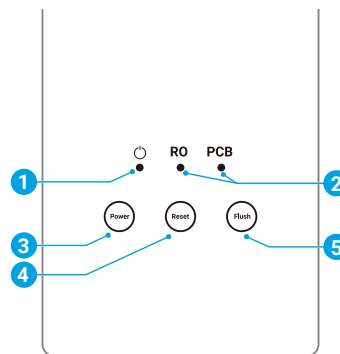

## Operational Specifications

Model No.	TROE1000COL
Rated Voltage / Frequency	100–125 V / 60 Hz
Rated Total Power	85 W
Feedwater Water Pressure	14–87 psi
Feedwater Requirement	Municipal Tap Water with TDS <500 ppm
Feedwater Temperature	40–100 °F ( 4.4–38 °C)
Operating Ambient Temperature	39–100 °F ( 4–38 °C)
Operating Ambient Humidity	≤90%

# Technical Specifications

Model No.	TROE1000COL
Daily Purified (RO) Production Rate	1000 GPD
Filtered Water Flow Rate	2.5 L/min
Purified Water Flow Rate	2.2 L/min
Recovery Rate	2:1
Product Dimensions (WxHxD)	5.2 x 16.6 x 18.2 in. (13.2 x 42 x 46.2 cm)
Net Weight	28.2 lb (12.8 kg)

## TDS Reduction Rates

Dispensed water should see a TDS reduction rate of up to 90%.\* Refer to the following table for estimated before and after TDS levels.

**NOTE:** TDS reduction rates may vary based on the quality of source water.

Inlet Water TDS Level	Dispensed Water TDS Level
500	50
450	45
400	40
350	35
300	30
250	25
200	20
150	15
100	10
50	5

\*Data based on controlled laboratory test conditions.

## Installation

### 1. Installation Overview

#### Materials Needed

- Variable speed drill
- 2 Drill bits: 1/4" for drainpipe, 1" for faucet hole
- Adjustable wrench
- Screwdriver
- Flashlight or headlamp
- Goggles or protective glasses
- Towel

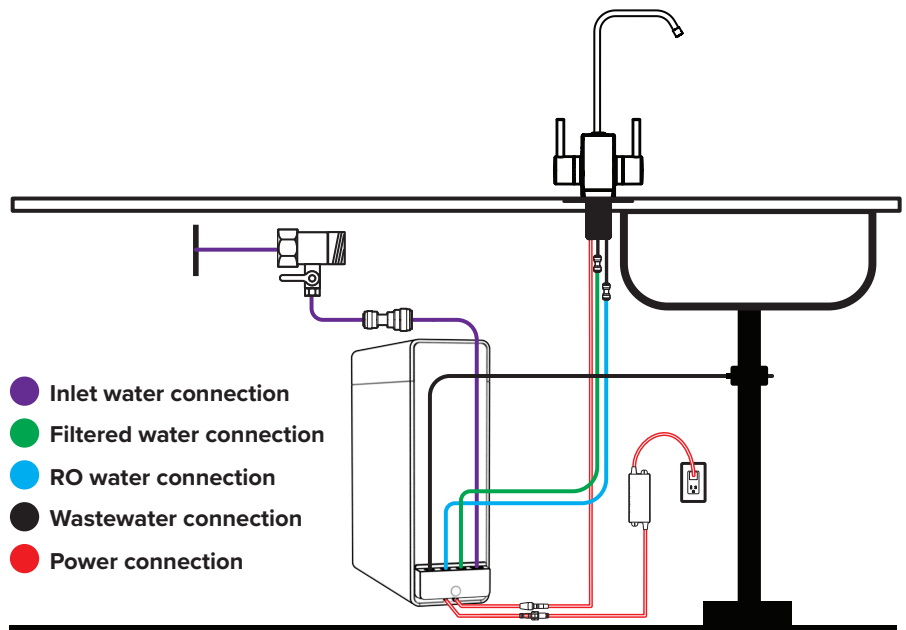

## 2. Connect to the Cold Water Supply

**CAUTION:** DO NOT CONNECT THIS WATER LINE TO A HOT WATER SUPPLY LINE. The water supply to the unit MUST be from the COLD WATER LINE. Using HOT WATER will severely damage your filters.

**NOTE:** Plumber's tape is included for use on any additional threaded connections you may need to make during installation. Do not use plumber's tape on included feedwater adapter, as it has a built-in gasket that creates a proper seal without tape.

- A. Turn off cold water supply. Open faucet and drain any remaining water in pipes.
- B. Using an adjustable wrench, disconnect cold water pipe from cold water supply line.
- C. Twist feedwater adapter (J) onto cold water supply line, then attach cold water pipe to the top of the feedwater adapter.

**NOTE:** In the event the cold water pipe has a 3/8-in. diameter, a 3/8-in. adapter nut is attached to the base of the feedwater adapter. Unscrew from base and twist on to top.

- D. The system must be used within indicated water pressure range. If your water pressure is high, a pressure reduction valve (I) has been included with the system. Install it on the 1/4-inch shut-off valve tube (R) after the feedwater adapter and before the shut-off valve on the tube. Use the tube cutter (N) to cleanly cut tubing. Install valve so that it aligns with the flow of water.

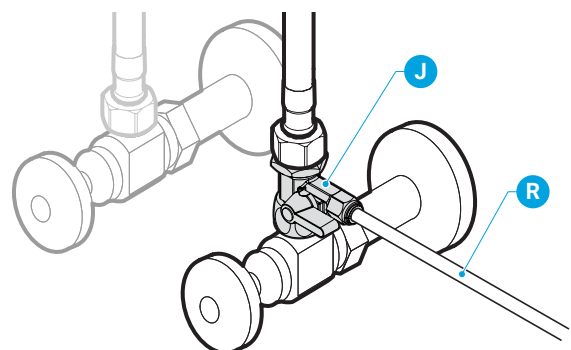
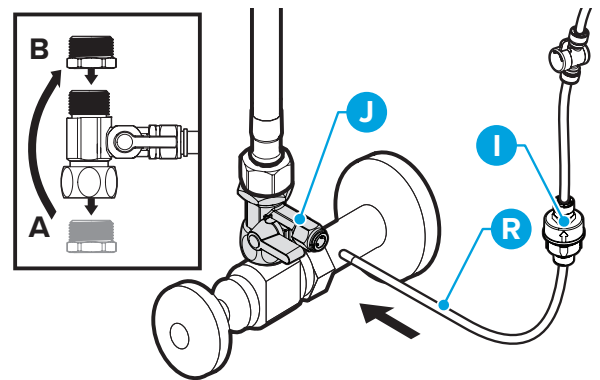
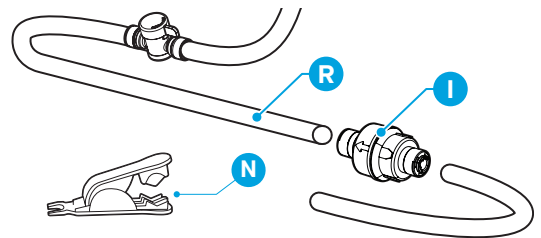
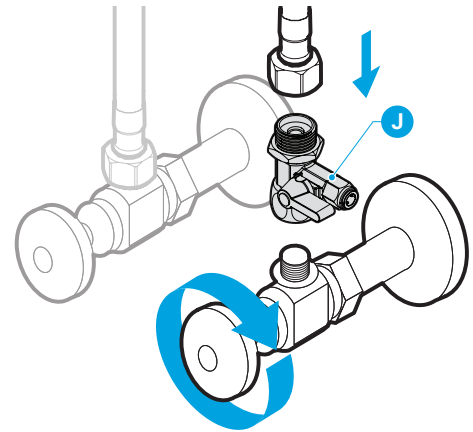

- E. Insert the shut-off valve tube (R) straight into the quick connect at the end of the feedwater adapter (J). Insert to the black line marked on the tube.
- F. Gently tug on the shut-off valve tube to ensure a secure connection with the feedwater adapter.

**IMPORTANT:** To remove tubing, ALWAYS press the gray collar on the fitting first to release. DO NOT attempt to remove tubing by pulling on it with out first releasing it. This may damage tubing and cause leakage.



### 3. Connect the RO Wastewater Tube

The drain saddle (K) is designed to fit around a standard 1.5 in. OD (outer diameter) drain pipe.

-  Always install the drain saddle before the P-trap and on a straight vertical or horizontal section of the pipe.
-  To avoid clogging the drain line with debris, do not install the drain saddle after the drain pipe meets a garbage disposal or dishwasher drain.

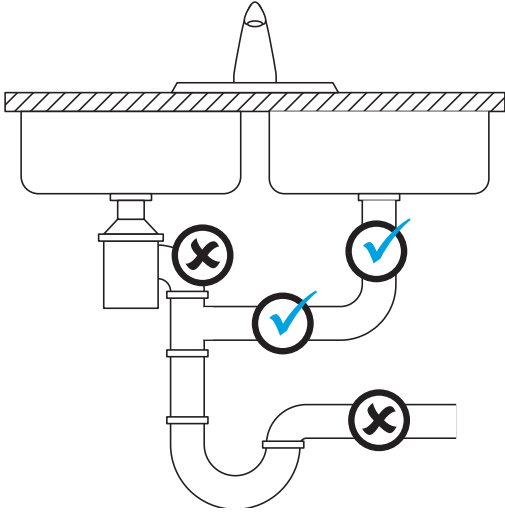

To make the wastewater drain connection:

- A.** Determine location for drain saddle (K). To guide drilling, make a mark on the pipe for opening (1).
- B.** Using adjustable drill with 1/4" drill bit, drill hole at mark. Drill hole in one side of pipe **ONLY**.
- C.** Remove the backing from the foam gasket. Align the adhesive side of it over the hole on the inside of the drain saddle. Press in place, ensuring a clean opening.
- D.** Position both halves of the drain saddle around the drain pipe, aligning the opening in the drain saddle directly over the drilled hole in the drain pipe. Insert the drill bit through both holes to ensure proper alignment.
- E.** Secure the drain saddle to the drain pipe using the provided nuts and bolts. **DO NOT** overtighten.
- F.** Insert the wastewater tube (S) into the quick connect of the drain saddle. Insert to the black line marked on the tube. Gently tug on the tube to ensure a secure connection.

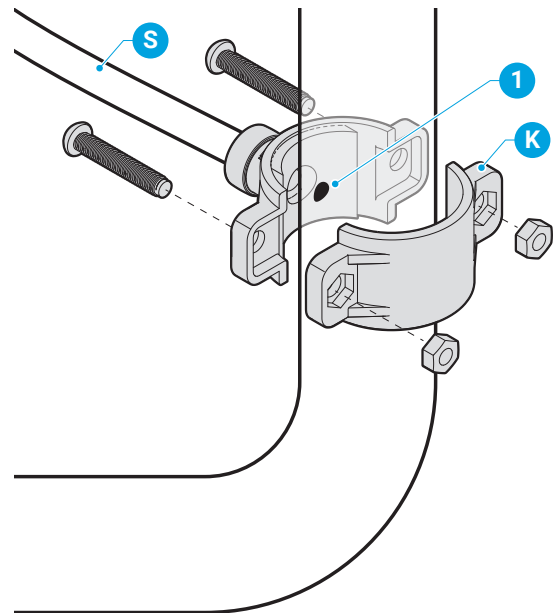

## 4. Install the Smart Faucet

**NOTE:** An optional faucet base (T) has been included to accommodate your sink hole. If using, thread power cord through it before mounting faucet on counter.

- A. Ensure that you have a faucet mounting hole in your sink or sink countertop for this faucet. If you do not, create a mounting hole no less than 1 – 1.2 in. (26 – 30 mm).
- B. Remove the washer (1) and lock nut (2) from the faucet. Ensure that you leave the O-ring (3) on the faucet. It nestles securely into a groove at the base of the faucet.
- C. Attach one 1/4 in. quick connect (H) to the ends of each of the faucet stems.

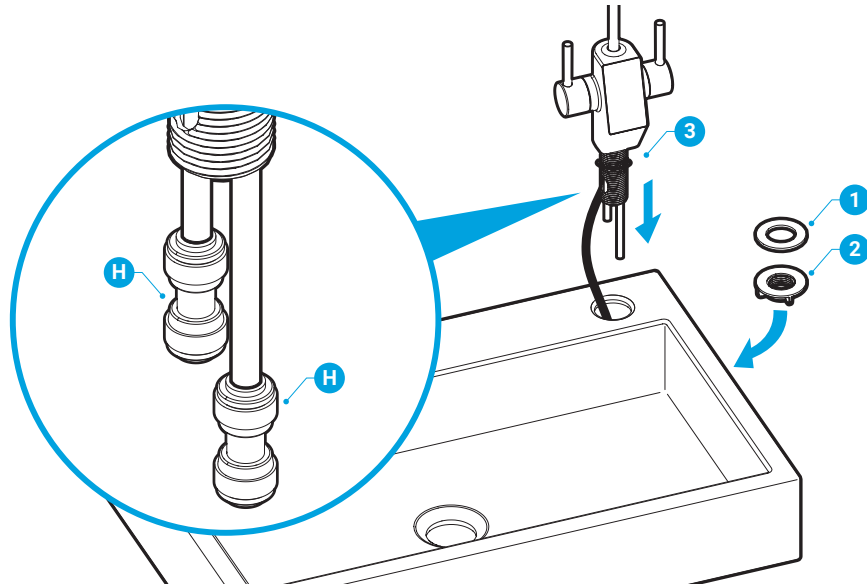

- D. Thread the faucet power cord through the mounting hole in the countertop. Insert the faucet into the mounting hole. Secure in place under the sink with the washer, followed by the locking nut.
- E. From underneath the sink, insert the white filtered water tube (Q) into the 1/4-in. quick connect on the shorter faucet stem. Insert the blue purified water tube (Q) into the 1/4-in. quick connect on the longer faucet stem. Slide a lock clip beneath each gray collar on quick connects to secure tubing in place.

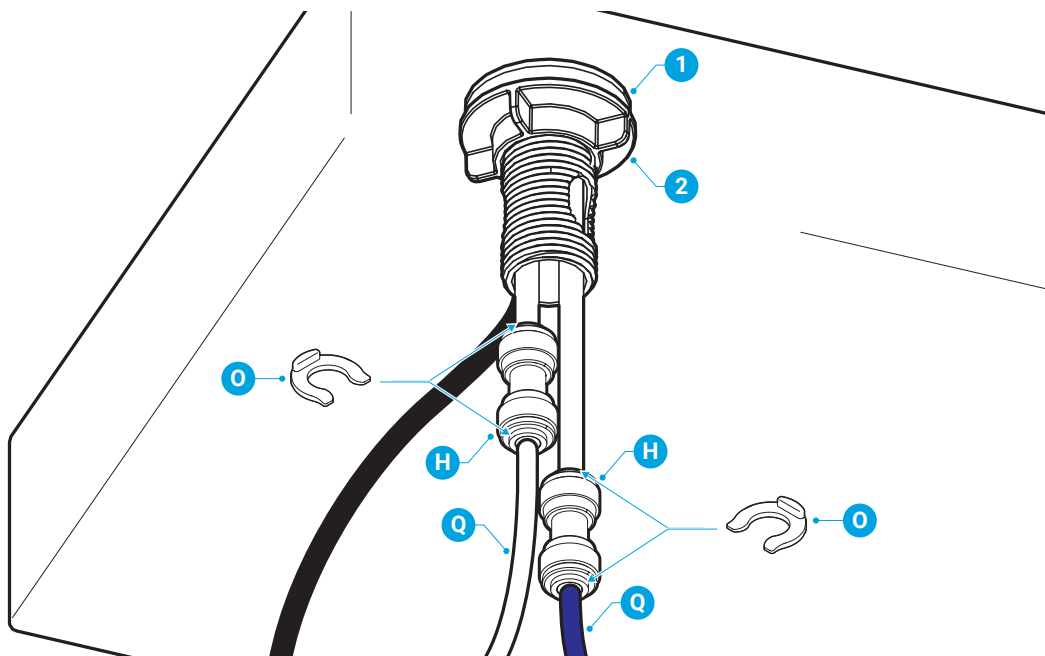

## 5. Complete the Installation

**IMPORTANT:** The filtration system has been fitted with protective plugs to ensure system ports are not damaged during shipping. Plugs **MUST BE** removed before connecting tubing. To remove plugs, slide release tool of tube cutter (N) around the base of the plug and over top of gray collar. Press down on gray collar to release the plug. **DO NOT** attempt to remove plugs by pulling them up without first releasing them. This may severely damage ports and cause water leakage.

- A. Connect the shut-off valve tube (R) to inlet water port (9).
- B. Connect white faucet tube (Q) to filtered water port (8).
- C. Connect blue faucet tube (Q) to the purified water port (7).
- D. Connect wastewater tube (S) to wastewater port (6).
- E. Slide one lock clip under each gray collar to ensure secure tube-port connections.

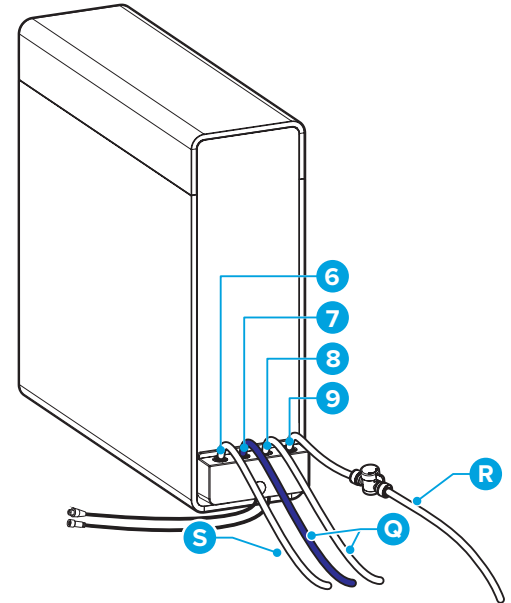
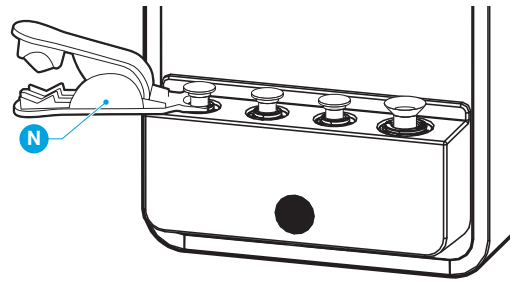

## Operation

### Start Up the Filtration System

- A. Ensure all water connections are completed as described in the Installation section.
- B. Turn the cold water supply on. Ensure the shut-off valve is open on the shut-off valve tube (R).
- C. Connect the smart faucet power cord to the smart faucet power cord connection (5), then attach the power cord with adapter to the system power cord connection (4). Plug the power cord with adapter into a 3-prong outlet. The system powers on. The power light illuminates. The filter reset and filter flush lights briefly flash, then steadily illuminate.
- D. The system will beep once, and the indicator panel and the smart faucet LED screen will turn on. The system will go into an automatic flushing mode, which lasts approximately 90 seconds.
- E. Rotate the smart faucet's RO handle (11) open. Allow the purified (RO) water to dispense for 5 to 6 minutes or until water runs clear. Do not drink this water. While system is flushing, ensure there are no system leaks.
- F. The system is now ready to dispense filtered and purified water.

**NOTE:** If the faucet dispenses water for more than 30 minutes, uninterrupted, the water filtration system enters overtime protection mode. The LED display screen flashes, and the filtration system is no longer able to produce water. To clear protection mode, close the handles on the smart faucet, press the power supply button until the unit powers off, then unplug the water filtration unit. Wait a few seconds, then plug unit back in.

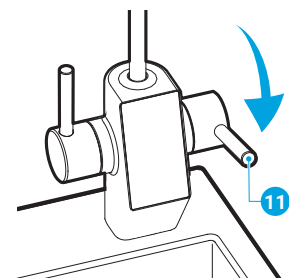
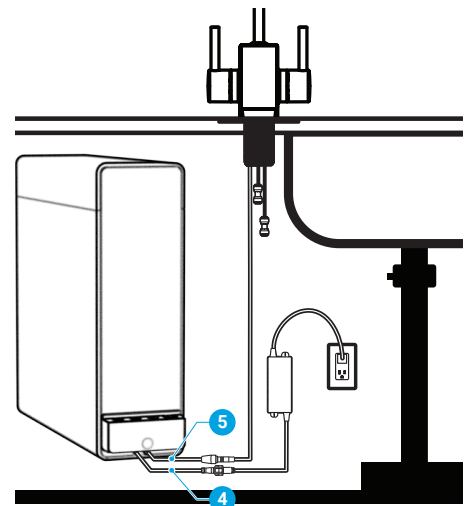

## Shutting Down the Water Filtration System

If the system will not be used for an extended period of time, turn off the shut-off valve on the shut-off valve tube (R), press the power supply button to turn the unit off, then unplug the water filtration system.

When the system is turned on again, it will go into automatic flushing mode to clear the filters.

## Care and Maintenance

- Keep the system in a cool, dry place away from direct sunshine.
- Use a clean, soft cloth to remove dust buildup. DO NOT use soap, detergent, or harsh abrasives.
- Never lay the water filtration system on its side or back. It should always be operated and stored in an upright position.
- If the cold water inlet temperature drops to 32°F (0°C), there is a risk the tubes could crack, and damaging leaking could occur. To prevent this, turn off the shut-off valve on the shut-off valve tube (R), then open the handles of the smart faucet and drain any remaining water out of the filtration system.

## Filter Replacement Schedule

Filter Type	Model No.	Replacement Schedule	Function
PCB	RPFTR0E1000COLP	6–12 months or 3,600 liters	Removes mud, sand, rust, and other suspended solids; also removes chlorine, and unpleasant tastes, odors, and colors.
RO	RPFTR0E1000COLR	12–24 months or 7,200 liters	Membrane rated at 0.0001 μ. Removes up to 99% of contaminants, including total dissolved solids, fluoride, and heavy metals like lead and arsenic.

## Replace Filters

When one or both of your filter indicator lights begin to flash, the filter(s) need to be replaced. To change filter:

- Press the power supply button on the unit until the unit powers off, then unplug power cord. Turn off the water supply. Open faucets and drain remaining water in system. Remove compartment cover of filter to be replaced.
- Grasp handle of expired filter and rotate counterclockwise to unlock from compartment. If you encounter resistance, use filter release tool (L). Once expired filter has been unlocked, remove from compartment.
- Insert new filter, rotating clockwise to lock into place. Filter handle should align with dot on RO filter system as shown in the below illustration. Reinstall compartment cover.
- Turn on water supply, then plug unit back in. Press and hold the reset button until filter indicator light stops flashing (approximately 3 seconds). Proceed to "Flushing the Filters" section.

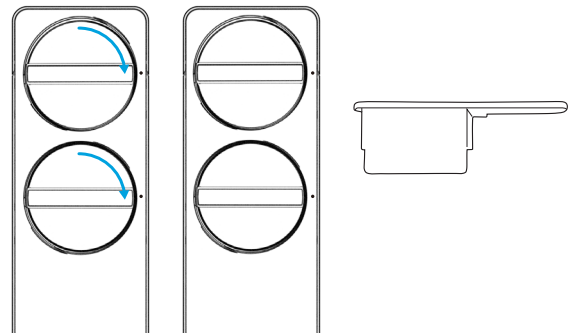

## Flushing the Filters

Always flush new filters before using. Open faucet. Press the flush button once. The flushing process takes approximately 60 seconds. To stop the flushing process at any time, press the flush button again.

**NOTE:** The flush button does not work when the system is in automatic flushing mode.

# Troubleshooting

Problem	Probable cause	Solution
The filters are generating a light noise during operation.	The filters will generate a light noise during operation.	This is normal.
The water output volume has dropped.	<ul style="list-style-type: none"> <li>• The filter is jammed.</li> <li>• The filter needs to be replaced.</li> <li>• The shut-off valve is not in the ON position.</li> </ul>	<ul style="list-style-type: none"> <li>• Flush or replace the filter.</li> <li>• Replace the filter.</li> <li>• Check the shut-off valve and the faucet handles to ensure they are in the ON position.</li> </ul>
The water quality is low.	<ul style="list-style-type: none"> <li>• The filter needs to be replaced.</li> <li>• The filtration system has not used for a long period of time (over 3 days).</li> <li>• The quality of the source water is low.</li> <li>• The ambient operating temperature is too low.</li> </ul>	<ul style="list-style-type: none"> <li>• Replace the filter.</li> <li>• Rotate the RO handle open and flush the system for 3-5 minutes.</li> <li>• Confirm that the water source is municipal tap water.</li> <li>• Increase ambient temperature.</li> </ul>
There is water leakage.	A component is damaged.	Immediately turn off water and power to the system, and contact customer service for assistance.
There is no water output after replacing a filter.	There is an air jam.	When replacing a filter, first press the power supply button to turn the unit off, unplug the water filtration system, then shut off the water supply. Replace the filter. Turn the water supply back on and plug in the water filtration unit.

# Warranty

Brio (“Vendor”) warrants to the original purchaser of the Brio Water Filtration System (the “Product”), and to no other person, that if the Product is assembled and operated in accordance with the printed instructions accompanying it, then for a period of one (1) year from the date of purchase, all parts in the Product shall be free from defects in material and workmanship. This Limited Warranty shall be limited to repair or replacement of parts, which prove defective under normal use and service and which Vendor shall determine in its reasonable discretion upon examination to be defective. To take advantage of this Limited Warranty, please follow these steps:

1. Please retain your sales slip or invoice, as Vendor may require reasonable proof of your date of purchase.
2. Contact Vendor’s Customer Service Department using the contact information listed below.
3. Return parts to Vendor, per Vendor’s instructions, at your cost and expense.
4. Upon receipt by Vendor, Vendor shall advise you in writing whether a defect covered by this Limited Warranty exists in any returned part and whether your claim has been approved or denied.
5. Upon Vendor’s approval of your claim, Vendor will replace such defective part without charge to you.

**WHAT THIS LIMITED WARRANTY DOES NOT COVER:** This Limited Warranty does not cover any failures or operating difficulties of the Product due to accident, abuse, misuse, alteration, misapplication, improper installation or improper maintenance or service by you or any third party, or failure to perform normal and routine maintenance on the Product, as set out in the User’s Manual. In addition, this Limited Warranty does not cover damages to the finish, such as scratches, dents, discoloration or rust after purchase.

This Limited Warranty is the only express warranty given on the Product and is in lieu of all other express warranties. Vendor disclaims all warranties for products that are purchased from seller other than authorized retailers or distributors. THIS LIMITED WARRANTY RESTRICTS THE DURATION OF ANY AND ALL IMPLIED WARRANTIES, INCLUDING WITHOUT LIMITATION, THE IMPLIED WARRANTY OF MERCHANTABILITY AND FITNESS FOR A PARTICULAR PURPOSE TO THE ONE (1) YEAR TERM OF THIS LIMITED WARRANTY. UPON THE EXPIRATION OF THE ONE (1) YEAR TERM OF THIS LIMITED WARRANTY, VENDOR DISCLAIMS ANY AND ALL IMPLIED WARRANTIES, INCLUDING WITHOUT LIMITATION THE IMPLIED WARRANTIES OF MERCHANTABILITY AND FITNESS FOR A PARTICULAR PURPOSE, THE PRODUCT BEING THUS SOLD AS-IS, WITH ALL FAULTS. FURTHER, VENDOR SHALL HAVE NO LIABILITY WHATSOEVER TO PURCHASER OR ANY THIRD PARTY FOR ANY SPECIAL, INDIRECT, PUNITIVE, INCIDENTAL, OR CONSEQUENTIAL DAMAGES. OTHER THAN THIS LIMITED WARRANTY, THERE ARE NO WARRANTIES WHICH EXTEND BEYOND THE DESCRIPTION ON THE FACE HEREOF. Vendor assumes no responsibility for any defects caused by third parties. This Limited Warranty gives you specific legal rights, and you may have other rights which vary from state to state. State law may also override statements in this Limited Warranty regarding the restriction on the duration of implied warranties. Some jurisdictions do not allow exclusion or limitation of special, incidental or consequential damages, or limitations on how long a warranty lasts, so the above exclusion and limitations may not apply to you.



[WWW.BRIOWATER.COM](http://WWW.BRIOWATER.COM)

©2025 Brio Water Technology, Inc.