



# 2-Stage Whole House Filtration System (4.5" x 20")

## Setup Manual

Model Nos.:

FSWH220STD, FSWH220PHO, FSWH220KDF

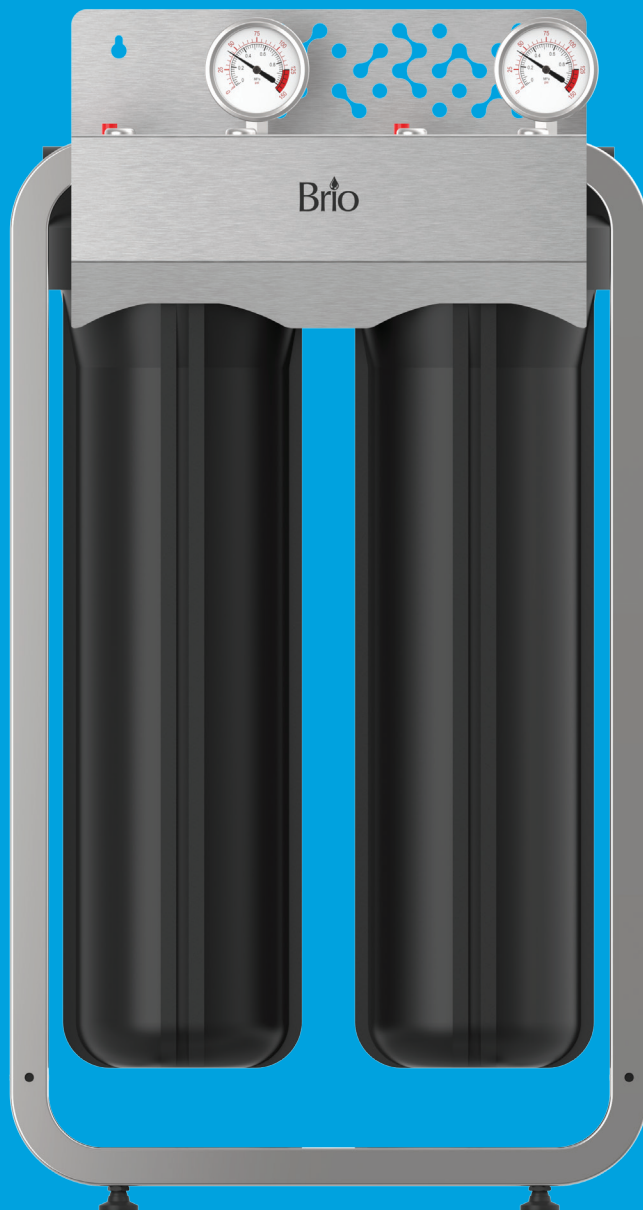

# Table of Contents

<b>Installation Conditions and Requirements</b> .....	<b>3</b>
<b>Product Overview</b> .....	<b>3</b>
Operational and Technical Specifications .....	4
<b>Installation</b> .....	<b>4</b>
Tools and Materials Needed .....	4
Parts Not Included .....	4
Pre-installation .....	5
Reversing the Filter Order .....	5
Installation Overview .....	7
Installing the Whole House Filtration System .....	7
Installing Filters .....	8
Restarting Water Flow and Flushing Filters .....	9
<b>Maintenance</b> .....	<b>9</b>
Filtration Systems and Replacement Filters .....	9
Filter Specifications .....	10
Replacing Filters .....	10
Cleaning Filter Housings .....	11
<b>Troubleshooting</b> .....	<b>11</b>
<b>Warranty</b> .....	<b>12</b>

# Installation Conditions and Requirements

- This filtration system should not be used with water that is microbiologically unsafe or of unknown quality without adequate disinfection before and/or after the system.
- This filtration system should be installed out of direct sunlight and in a sheltered area that is level and dry, with no exposure to extreme hot or cold temperatures.
- If your feedwater is prone to pressure spikes over 80 psi, a pressure reduction valve should be installed before the feedwater enters the filtration system.
- When installing the system, follow all local plumbing and building codes.
- Use plumber’s tape on all threaded fittings.

## Product Overview

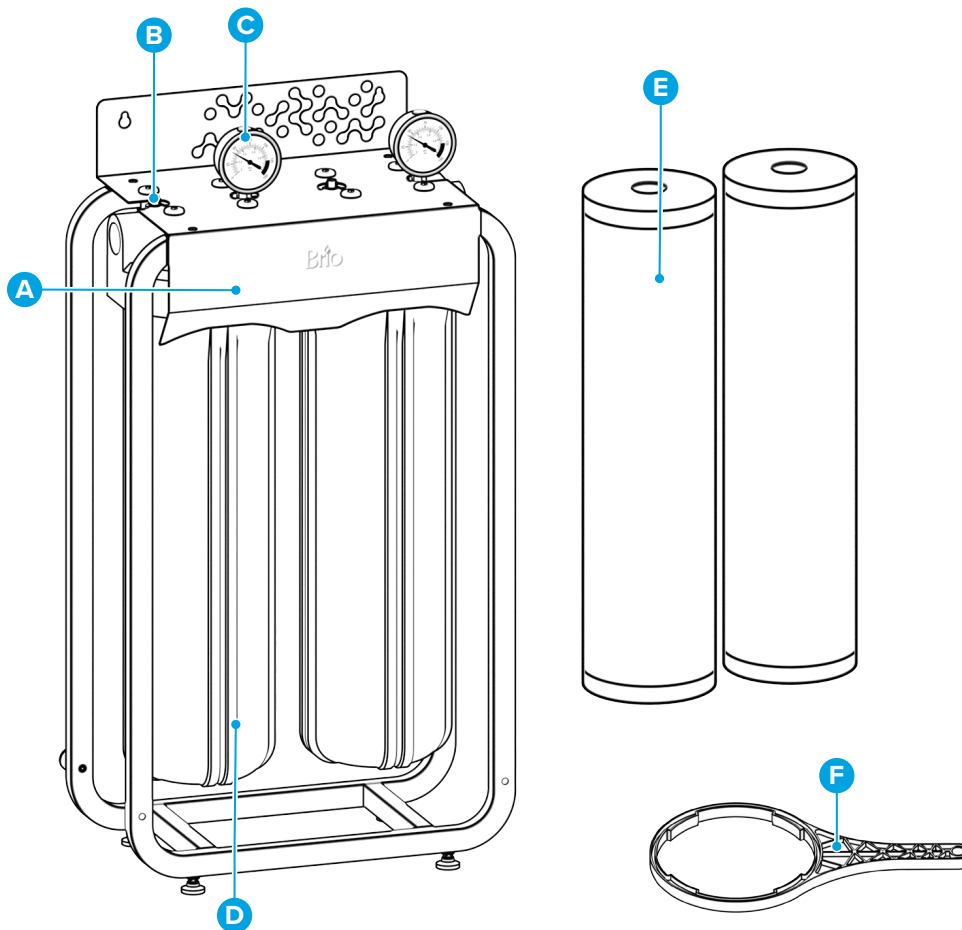

Part	Description
A	Filtration system bracket
B	Pressure release button (x2)
C	Pressure gauge (x2)

Part	Description
D	Filter housing (x2)
E	Filter (x2)
F	Filter housing wrench

## Operational and Technical Specifications

Models	FSWH220STD, FSWH220PHO, FSWH220KDF
Minimum Feedwater Pressure	45 psi
Maximum Feedwater Pressure	80 psi
Maximum Working Pressure	150 psi
Operating Feedwater Temperature	41-113 °F (5-45 °C)
pH Range	6.0–9.0
Maximum Flow	15 GPM / 900 GPH
Filter Life Cycle	6-12 Months
System Dimensions (WxHxD)	16.19 x 30.61 x 8.77 (41.12 x 77.75 x 22.27 cm)

## Installation

### Tools and Materials Needed

Safety glasses	Pipe wrench	<b>Additional Tools You May Need:</b>
Towels	Pipe cutter	Soldering iron or torch
Bucket	Plumber's tape	Power drill
Allen wrench	Silicone lubricant	Deburring tool
Medium crescent wrench	Pipe wrench	

### Parts Not Included

Shut-off valves – x4 (x2 if no bypass)
1" male NPT threaded adapters – x2
Additional piping
Pipe hangers
Pressure reducing valve – x1
Ground jumper wire – x1 (if mounting on metal pipes)
Mounting screws (if wall-mounting system) – x2

## Pre-Installation

- This filtration system should be installed on the main water supply line near where it enters the house but after the main shut-off valve for the whole house.
- If your main water supply line branches off to indoor and outdoor lines, you may decide to install the filtration system on the indoor line if that's the only water you want filtered.
- We recommend configuring the setup so that the installation can accommodate a bypass loop. This will make servicing the filtration system easier.
- The filtration system can either sit on the floor in its bracket, or it can be mounted on a wall. If you plan to mount the system off the floor, ensure the wall can support the weight of the system when filled with water.
- Confirm the feedwater inflow direction.

## Reversing the Filter Order

Depending on where the main water supply line enters your home, you may need to reverse the filter order of the system to ensure feedwater enters Stage 1 first. To do so, follow these steps:

- Using the filter wrench, unscrew the filter housings from their caps and set them aside.
- Unscrew the pressure gauges by hand from the top of the bracket and set them aside.
- Using the Allen wrench, remove the 8 button-head screws on the top of the bracket to disconnect the pre-installed caps union.

**NOTE:** Leave the caps connected to each other and be sure to note the direction orientation of the union.

- Rotate the caps union 180 degrees. The housing cap that was on the right should now be on the left.

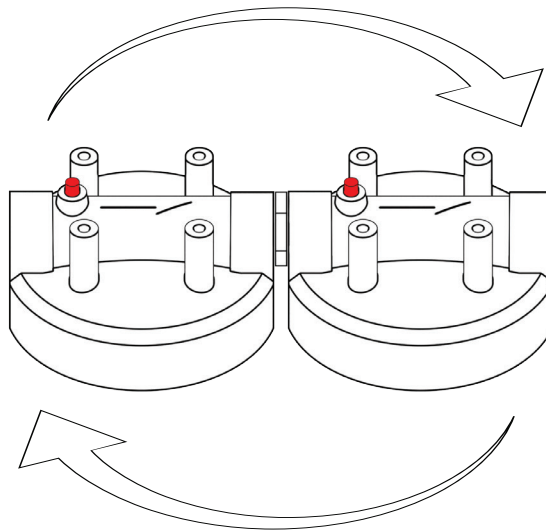

- Reattach the caps union to the bracket, securing with the button-head screws. Reinstall the pressure gauges. The red press-release buttons and pressure gauges should now be in a reversed position.

Before Reversing Filter Order:

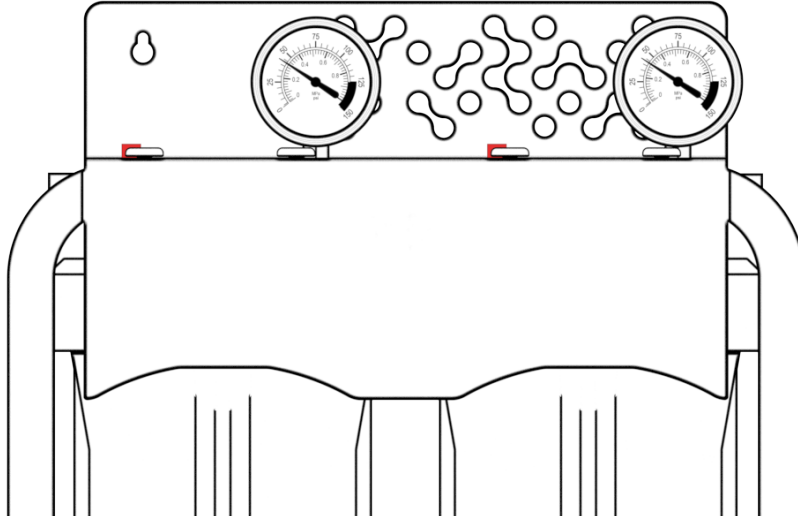

After Reversing Filter Order:

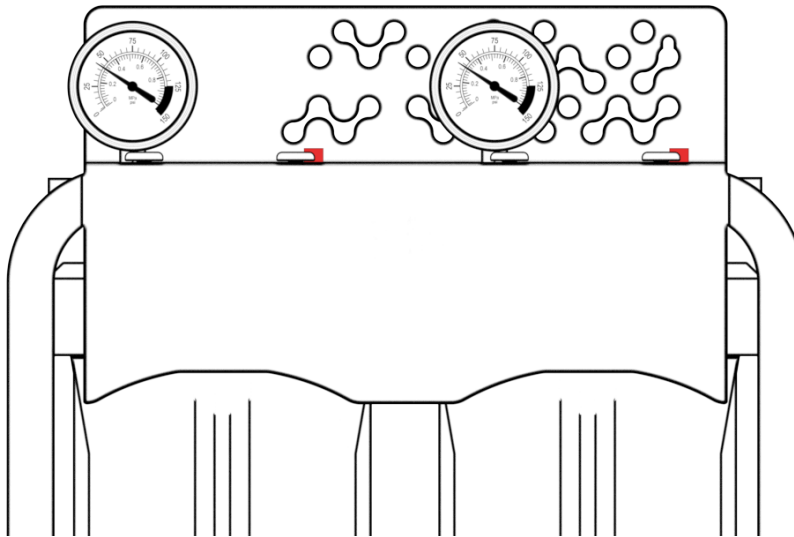

- Remove the packaged filters from the filter housings and set them aside in a safe place. Reinstall the empty filter housings. Hand tighten, then use the filter wrench to securely connect.

You have successfully reversed the filter order of the filtration system.

## Installation Overview

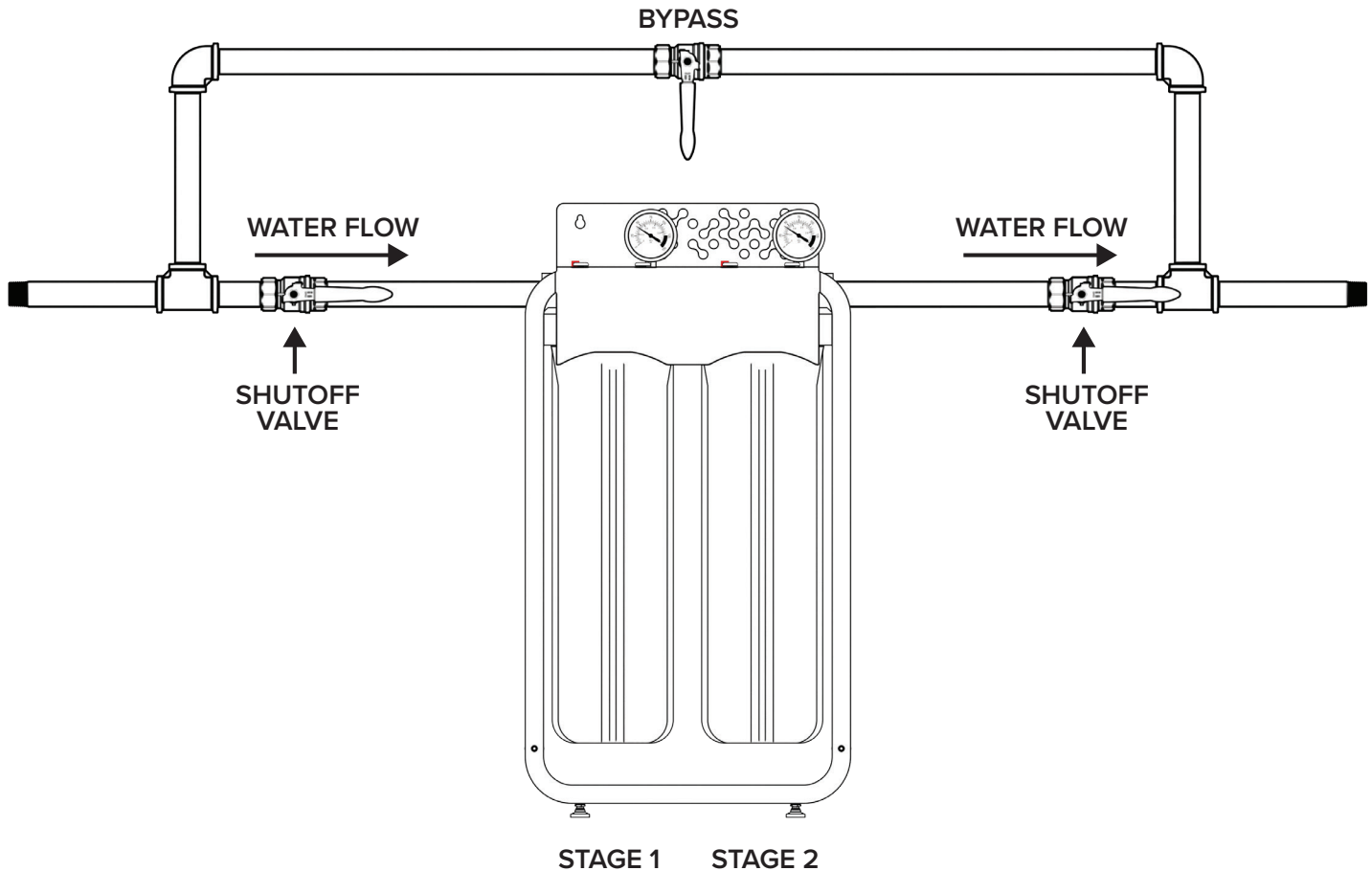

## Installing the Whole House Filtration System

**IMPORTANT:** Installation of this system requires draining your home's entire plumbing system and shutting down your water heater. Additionally, it may include installing components like a ground jumper wire and pressure reduction valve. If you are at all hesitant to proceed with the installation, we strongly recommend consulting or hiring a licensed plumber.

- Water pressure will have to be reduced in your plumbing system. Turn off the main water supply to the entire house and drain the plumbing system. Turn off the water heater.
- Carefully measure the section of the water line to be removed to accommodate the filtration system.

**IMPORTANT:** When determining the length of pipe to be removed, be sure to account for width of system, shut-off valves, bypass system, and any other components and fittings.

- Place towels and a bucket beneath where you plan to cut the pipe. Cut the pipe using the appropriate tool for the pipe medium.

**NOTE:** Water will drain from pipe. Allow it to completely drain onto towels or into bucket. Once water has finished draining, mop up water as needed.

- Use deburring tool to smooth any jagged or nicked edges of pipe that will connect to the filtration system. Cut ends should be smooth and perpendicular.
- Attach necessary pipes, valves, and fittings to each side of the system. Install bypass if desired. Use plumber's tape on all connections.

## Installing Filters

- Remove filter housings from bracket. Rinse thoroughly to remove any dirt or dust that may have collected. Dry with a clean cloth.
- With clean hands, carefully remove all wrapping and labels from each filter. There is a raised alignment stand at the bottom of each housing. Insert the new filter into the housing so that the center hole at the bottom of the filter fits securely over the alignment stand of the housing. The filter must be seated properly.

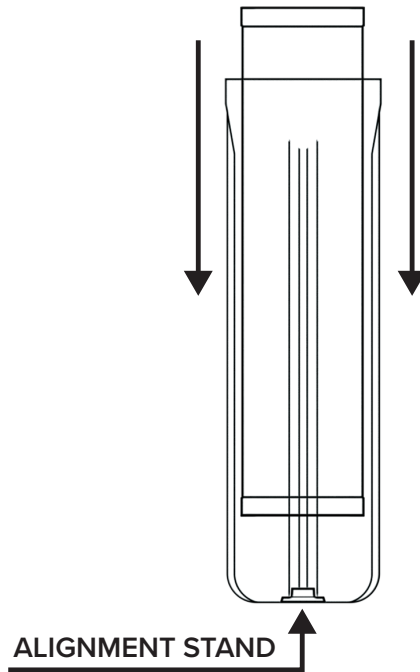

- Reattach housings by hand-tightening them loosely to caps union. Filters should be installed so that filtration stages align with flow of water. See “Installation Overview” for reference. Use the filter wrench to fully tighten housing connection, being careful not to overtighten.

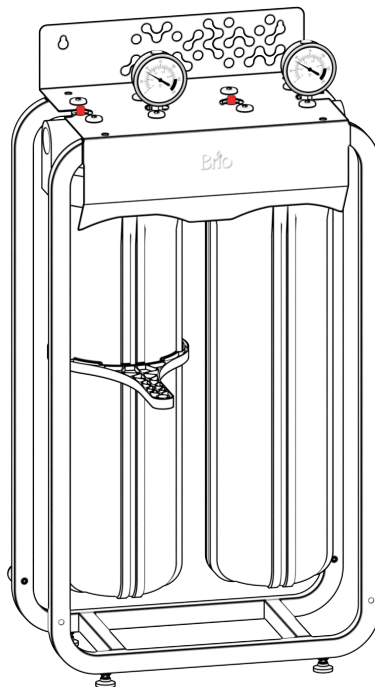

## Restarting Water Flow and Flushing Filters

- Open the valves to and from the water filtration system.
- Slowly turn on the main water supply. You will hear the sound of water entering the filtration system. Once the filtration system is filled with water, the sound will stop.
- Find the nearest water faucet in your home. Turn on the COLD WATER FAUCET ONLY.

**WARNING:** DO NOT use hot water to flush the filtration system.

- While the cold water runs, monitor the filtration system and connections for any leaks.
- The water will be gray or blackish as loose carbon particles are flushed from the system. Run water until it becomes clear, then continue to run water for another 5 minutes. Turn off cold water faucet.
- Wait 30 minutes, then run the cold water for an additional 10 minutes.
- Turn off cold water faucet.
- Remember to turn on your hot water heater.

The 2-Stage Whole House Filtration System is now ready to use. During the first week of use, occasionally check the system for leaks and ensure all connections remain secure.

**NOTE:** Cloudiness in your water may continue for up to a week as your system expels air bubbles. This is normal. The air bubbles are harmless and water can be used as normal.

## Maintenance

### Filtration Systems and Replacement Filters

Model	Sediment RFCTY45205PP 4.5" x 20"	CTO RFCTY45205CTO 4.5" x 20"	GAC + KDF RFCTY4520KDF 4.5" x 20"	PHO RFCTY4520PHO 4.5" x 20"
FSWH220STD	Stage 1	Stage 2	—	—
FSWH220KDF	Stage 1	—	Stage 2	—
FSWH220PHO	—	Stage 2	—	Stage 1

— = Not included with indicated model number but can be used with filtration system.

## Filter Specifications

Filter	Type	Material	Contaminant Reduction*	Life Cycle**
Sediment	5-micron polypropylene (PP)	Layered pure PP microthread	Rust, silt, color, suspended solids	6–12 months / 100,000 Gallons
CTO	5-micron carbon block	PP shell, silicon ring, coconut husk carbon block	Cadmium, hexavalent chromium, PBBs, PBDEs, industrial solvents	6–12 Months / 100,000 Gallons
GAC + KDF	Kinetic degradation fluxion (compound)	Catalytic carbon, copper, zinc	Chlorine, lead, mercury, hydrogen sulfide, pesticides, herbicides	6–12 Months / 100,000 Gallons
PHO	Sodium polyphosphate	Slow dissolve sodium polyphosphate crystal balls	Scale inhibitor and corrosion reduction	6–12 Months / 250,000 Gallons

\*Filters are not designed to reduce total dissolved solids (TDS). Instead, they retain healthy minerals while removing harmful contaminants.

\*\*Life cycle is dependent on source water quality.

## Replacing Filters

If you notice your water flow slowing or the pressure gauges on the filtration are registering <12 psi, the filters have reached end of life, and it's time to replace them.

- Turn off the water supply to the system. Open a nearby cold water faucet and drain water to reduce pressure on the system. Shut off faucet once flow stops.
- One by one, press red pressure-release buttons on top of bracket. A small amount of air and/or water will be expelled as the pressure is released.
- Using the filter wrench, unscrew the filter housings. Carefully remove the O-ring from the top of each filter housing, then set aside in a clean, safe place. If O-rings are stretched, crimped, or damaged in any way, replace them with new O-rings.
- Remove the old filters from housings and discard.

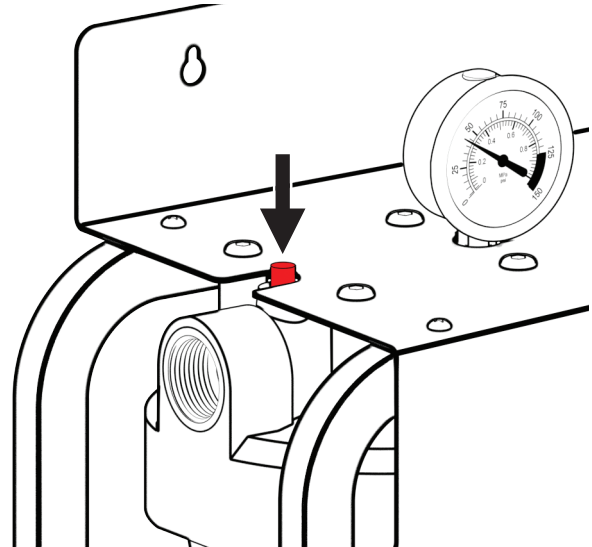

## Cleaning Filter Housings

We recommend cleaning the filter housings at least once a year. To do this, gather the following supplies:

- 1 tablespoon household bleach
  - 1 gallon warm water
  - Clean cloths or rags
  - Protective gloves
- Create a cleaning solution by mixing 1 tablespoon of household bleach with one gallon of warm water.
  - Soak a clean cloth in the solution then scrub the inside and outside of each housing, and underside of caps union. Wear gloves to protect hands.
  - Rinse housings and caps union thoroughly with fresh water. Remove ALL traces of bleach. Dry housings and caps union with a clean cloth.

**CAUTION:** Do NOT directly add bleach to any part of the system.

- Apply silicone lubricant to O-rings, then reinsert them into housing grooves. Ensure they are fully seated and flush with the top of the groove. Apply silicone lubricant to the threads of the filter housing.
- Follow instructions on pages 8-9, “Installing Filters” and “Restarting Water Flow and Flushing Filters,” to install and flush new filters.
- The 2-Stage Whole House Filtration System requires minimal maintenance, however, after extended periods of non-use, such as vacation, we recommend you flush the filtration system for at least 10 minutes before using water.

## Troubleshooting

Problem	Solution
Water flow is slow or has slowed over time.	<ul style="list-style-type: none"> <li>• If the filtration system has been working properly, but you’ve recently noticed water flow slowing, filters have likely reached end of life. Depending on quality of feedwater, it’s strongly recommended that filters be changed every 6 to 12 months. See page 10, “Replacing Filters.”</li> </ul>
Water flow is slow immediately after filter installation.	<ul style="list-style-type: none"> <li>• One or more of the filters may be incorrectly installed. Reinstall filters.</li> <li>• High-flow fixtures and faucets, like multi-headed showers, body sprayers, and bathtub and utility sink faucets, should be avoided for the first 72 hours. Using a high-flow fixture in the first 72 hours may result in a temporary carbon blockage. To clear blockage, turn off running water for at least 10 minutes. Turn water back on and use at low or normal flow rates.</li> </ul>
Water is cloudy or grayish.	<ul style="list-style-type: none"> <li>• Water may appear cloudy up to a week after initial system installation. The cloudiness/grayness is caused by air bubbles and residual carbon dust being expelled from the system. This is normal.</li> </ul>
The filter housing is leaking.	<ul style="list-style-type: none"> <li>• The O-ring may be incorrectly installed or damaged. If after reinstalling the O-ring the housing still leaks, contact customer service for assistance.</li> </ul>

# Warranty

Brio (“Vendor”) warrants to the original purchaser of the Brio Water Filtration System (the “Product”), and to no other person, that if the Product is assembled and operated in accordance with the printed instructions accompanying it, then for a period of one (1) year from the date of purchase, all parts in the Product shall be free from defects in material and workmanship. This Limited Warranty shall be limited to repair or replacement of parts, which prove defective under normal use and service and which Vendor shall determine in its reasonable discretion upon examination to be defective. To take advantage of this Limited Warranty, please follow these steps:

1. Please retain your sales slip or invoice, as Vendor may require reasonable proof of your date of purchase.
2. Contact Vendor’s Customer Service Department using the contact information listed below.
3. Return parts to Vendor, per Vendor’s instructions, at your cost and expense.
4. Upon receipt by Vendor, Vendor shall advise you in writing whether a defect covered by this Limited Warranty exists in any returned part and whether your claim has been approved or denied.
5. Upon Vendor’s approval of your claim, Vendor will replace such defective part without charge to you.

**WHAT THIS LIMITED WARRANTY DOES NOT COVER:** This Limited Warranty does not cover any failures or operating difficulties of the Product due to accident, abuse, misuse, alteration, misapplication, improper installation or improper maintenance or service by you or any third party, or failure to perform normal and routine maintenance on the Product, as set out in the User’s Manual. In addition, this Limited Warranty does not cover damages to the finish, such as scratches, dents, discoloration or rust after purchase.

This Limited Warranty is the only express warranty given on the Product and is in lieu of all other express warranties. Vendor disclaims all warranties for products that are purchased from seller other than authorized retailers or distributors. THIS LIMITED WARRANTY RESTRICTS THE DURATION OF ANY AND ALL IMPLIED WARRANTIES, INCLUDING WITHOUT LIMITATION, THE IMPLIED WARRANTY OF MERCHANTABILITY AND FITNESS FOR A PARTICULAR PURPOSE TO THE ONE (1) YEAR TERM OF THIS LIMITED WARRANTY. UPON THE EXPIRATION OF THE ONE (1) YEAR TERM OF THIS LIMITED WARRANTY, VENDOR DISCLAIMS ANY AND ALL IMPLIED WARRANTIES, INCLUDING WITHOUT LIMITATION THE IMPLIED WARRANTIES OF MERCHANTABILITY AND FITNESS FOR A PARTICULAR PURPOSE, THE PRODUCT BEING THUS SOLD AS-IS, WITH ALL FAULTS. FURTHER, VENDOR SHALL HAVE NO LIABILITY WHATSOEVER TO PURCHASER OR ANY THIRD PARTY FOR ANY SPECIAL, INDIRECT, PUNITIVE, INCIDENTAL, OR CONSEQUENTIAL DAMAGES. OTHER THAN THIS LIMITED WARRANTY, THERE ARE NO WARRANTIES WHICH EXTEND BEYOND THE DESCRIPTION ON THE FACE HEREOF. Vendor assumes no responsibility for any defects caused by third parties. This Limited Warranty gives you specific legal rights, and you may have other rights which vary from state to state. State law may also override statements in this Limited Warranty regarding the restriction on the duration of implied warranties. Some jurisdictions do not allow exclusion or limitation of special, incidental or consequential damages, or limitations on how long a warranty lasts, so the above exclusion and limitations may not apply to you.









[WWW.BRIOWATER.COM](http://WWW.BRIOWATER.COM)

©2025 Brio Water Technology, Inc.