

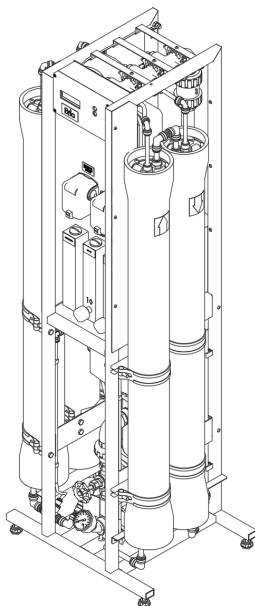

Instruction manual

BRIO commercial RO system

CROS4591



If you have any questions or concerns when installing, operating, or maintaining your reverse osmosis system, call our free number:

+1 (844) 257 4103

or visit briowater.com

When you call, please be prepared to provide the model, date code and serial number of your product.

MADE IN UKRAINE

Distributed by Brio Water
Technology, Inc.
City of Industry, CA 91745 ©2024
Brio® is a registered trademark of
Brio Water Technology, Inc.

CONTENTS		
1	Acronyms and abbreviations	3
2	RO system	3
2.1	Overview	3
2.2	Technical specifications	4
2.3	Product water capacity charts	7
3	Installation and startup	9
4	Installation requirements	14
5	Operating requirements	14
6	Shipping and storage requirements	16
7	Troubleshooting	16
8	Controller	18
8.1	Overview	18
8.2	Input & output specifications	18
8.3	Operating modes	19
8.4	Program settings	21
Annex A. Technological schemes		26
Annex B. Wiring diagram		30
Annex C. Piping layout		31
Annex D. Operating record		33
9	Warranty	34

1. ACRONYMS AND ABBREVIATIONS

CIP — Clean-in-place

FF — Forward flush

NC — Normally closed

NO — Normally open

TDS — Total dissolved solids

PPM — parts per million

PCB — Printed circuit board

P&ID — Pipe and instrument diagram

RO — Reverse osmosis

GPM — Gallon per minute

GPD — Gallon per day

PSI — pounds per square inch

2. RO SYSTEM

2.1. OVERVIEW

Brio reverse osmosis systems are used for demineralization the water with a salt content of 1500 ppm in industrial, municipal and commercial applications. Brio RO system can be used to demineralize low to medium salinity feed water. System components comprise carbon steel skid, high pressure pump, array of pressure vessels with membranes, power cabinet, process controller, and the necessary valves and instruments.



This appliance is not intended for use by persons (including children) with reduced physical, sensory or mental capabilities, or lack of experience and knowledge, unless they have been given supervision or instruction concerning use of the appliance by a person responsible for their safety. Children should be supervised to ensure that they do not play with the appliance.

Brio RO systems operate as follows.

The high pressure pump feeds the water into the membrane module or membrane array, in which feed water undergoes separation process and splits into permeate and concentrate streams.

Permeate (purified water) goes to the permeate outlet and is collected in water tank. Permeate line is also fitted with a pressure switch to halt the unit if significant pressure builds in permeate line indicating a full pressurized tank or pipeline shutoff.

Part of the concentrate stream is discharged to drain via drain rotameter. The rest goes back to the suction end of the high pressure pump via recycle rotameter.

Flow rates of drained and recycled concentrate have to be regulated to specified ranges in the Technical specifications with the regulating valves built in the rotameters.

The controller receives temperature and conductivity of permeate, permeate level, pressure switch statuses, and external inhibition signals.

It is recommended to review the installation diagrams of complex water treatment systems that include a reverse osmosis system. The installation diagrams are given in **Annex A**.

2. RO SYSTEM

2.2. TECHNICAL SPECIFICATIONS

Table 1. Physical parameters

MODEL	CROS4591
Rated capacity, GPD*	8 800
Membranes quantity	4
Rated voltage	220 V, 60 Hz
System electrical power, HP (kw)	2.2 (1.6)
Dimensions (Wid × Dep × Hgt), inch	20 × 16 × 58
Approx. weight (bare/crated), lbs	210/240
System water piping connection ports (feed water, permeate, drain)	1 "
Operating parameter specifications**	
Permeate flow, GPM	5.4
Concentrate flow rate, GPM	1.8
Concentrate recycle flow rate, GPM	22
Inlet water consumption (production), GPM	7.2

* For 74 °F, 375 ppm feed water, DuPont FilmTec™ XLE PRO-4040 membrane, flow factor 1

**Feed water must comply with requirements in Table 2. If some parameters do not meet the requirements, it is recommended to contact your product support for advice.

Table 2. Operating parameters

Parameter	Value***
Required supply water pressure	15 – 60 PSI
Water temperature	40 – 80 °F
Operating pressure	120 – 180 PSI



Tap feed water must be pre-filtered from fine particles and chlorine before entering the RO system. Well water may contain impurities such as hardness, iron, manganese, silica, hydrogen sulfide that can quickly lead to membrane failure. Some of these challenges can be addressed by using injection of antiscalant. Perform a detailed laboratory analysis of your well water and consult a water treatment specialist to see if you need additional equipment for treating your well water.

2. RO SYSTEM

Table 3. Influent water quality

Parameter	Value***
Hardness	9 gpg (150 ppm CaCO ₃)
Iron	0.1 ppm
Manganese	0.05 ppm
Silica	20 ppm
Total dissolved salts	1500 ppm
APHA color	15 degrees
Residual Chlorine	0.1 ppm
Hydrogen Sulfide	none

***Some limitations may not apply if using antiscalant, oxygen scavenger, or other type of chemical pretreatment.

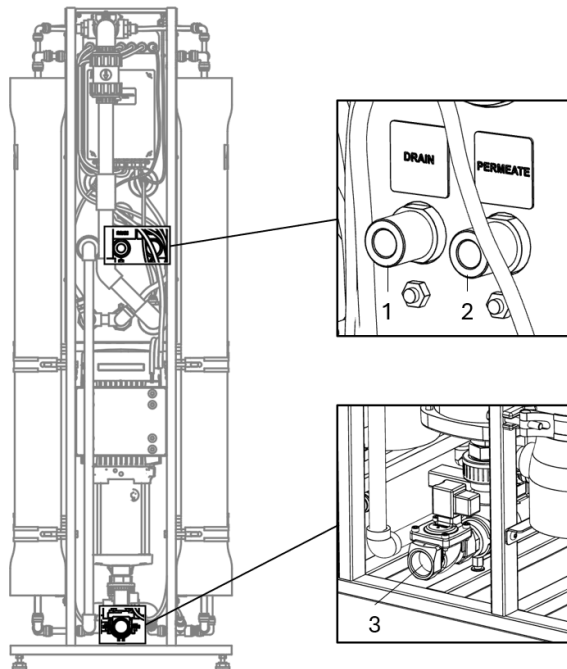

1 - permeate, 2 - drain, 3 - feed water

Figure 2.1 CROS4591 system water piping connection ports

2. RO SYSTEM

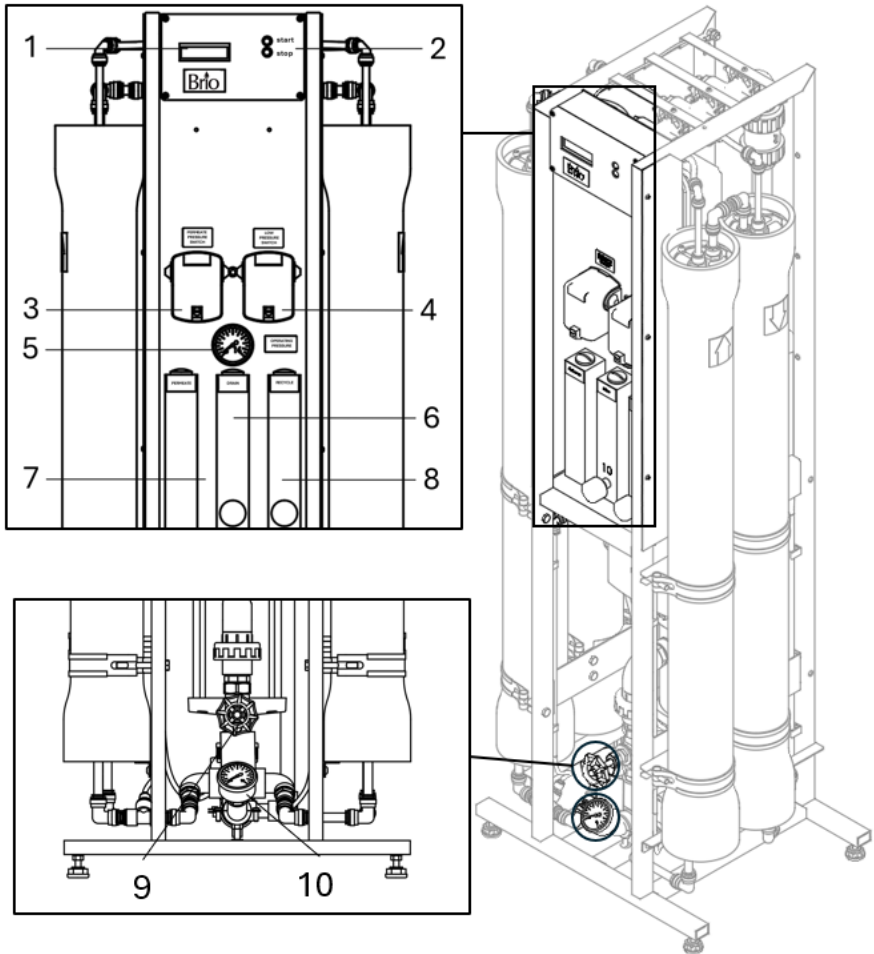

- 1 – OC5000 controller screen, 2 – ► START and ■ STOP buttons, 3 – permeate pressure switch, 4 – low pressure switch, 5 – operating pressure gauge 6 – drain rotameter, 7 – permeate rotameter, 8 – concentrate rotameter, 9 – pump throttle valve, 10 – inlet pressure gauge.

Figure 2.2 CROS4591 system control elements:

2. RO SYSTEM

2.2. PRODUCT WATER CAPACITY CHARTS

Permeate flow rates are calculated under the following conditions:

- 30 PSI influent water pressure
- 0 PSI backpressure in the permeate line
- flow factor 0.85 (flux decline equivalent to 3 years of use)

Your system's flow capacity may be different depending on the above factors and water chemistry.

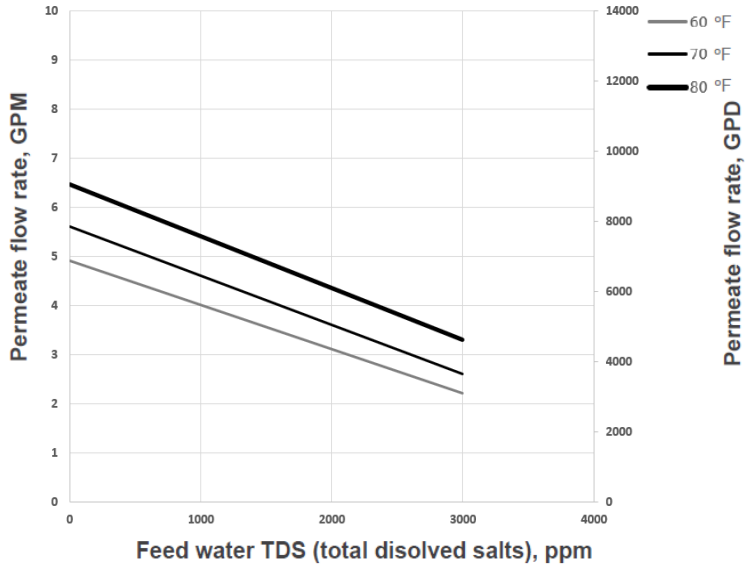

Figure 2.3 CROS4591 flow rate chart with XLE PRO-4040 membranes

2. RO SYSTEM

Permeate flow rates are calculated under the following conditions:

- 30 PSI influent water pressure
- 0 PSI backpressure in the permeate line
- flow factor 0.85 (flux decline equivalent to 3 years of use)

Your system's flow capacity may be different depending on the above factors and water chemistry.

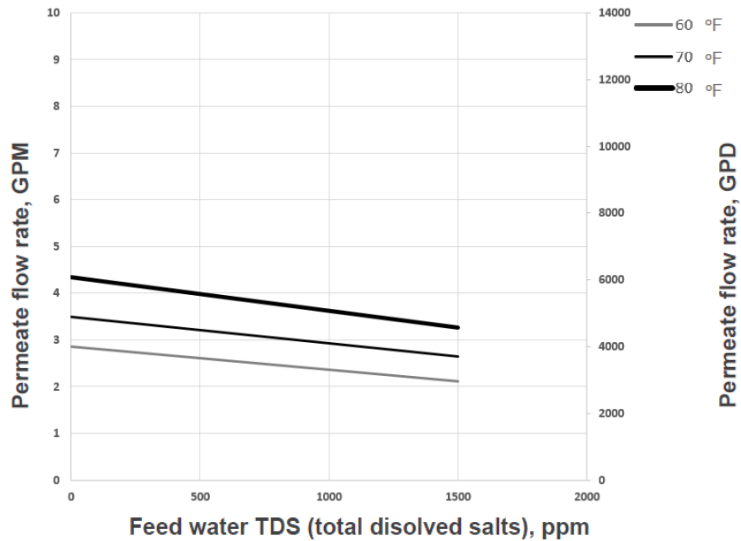

Figure 2.4 CROS4591 flow rate chart with TW30 PRO-4040 membranes

3. INSTALLATION AND STARTUP



CAUTION! Electrical installation should only be done by a qualified electrician.

3.1 Rest the unit on a flat level surface suitable for its weight (see Table 1). Inspect the RO system carefully for damage, including piping, valves and instruments, pump, pressure vessels, pre filter housings, power cabinet before proceeding with connection and startup.



*A sediment filter must be installed before the reverse osmosis system.
It is recommended to install a polypropylene cartridge with a filtration rate of 5 microns.*

Permeate to hydraulic accumulator /
storage tank

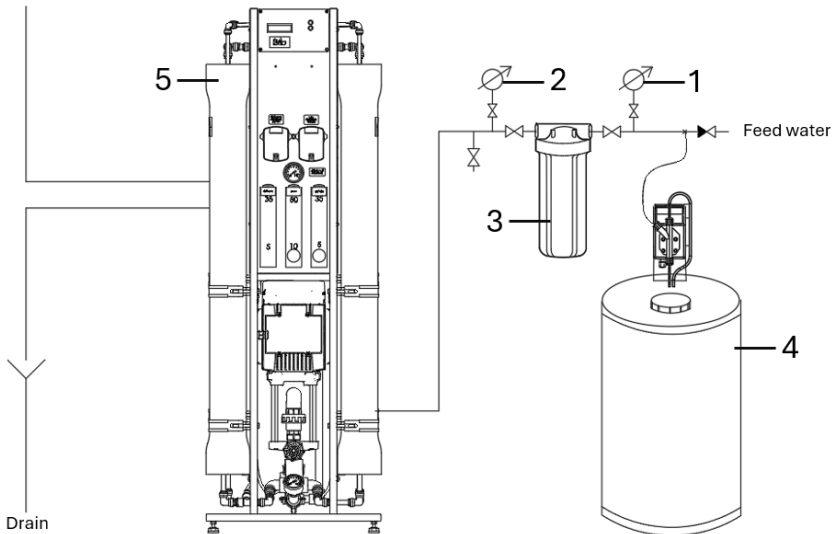

1- pressure gauge before filter, 2 – pressure gauge after filter, 3 – sediment inline prefilter,
4 – dosing station, 5 – reverse osmosis system

Figure 3.1 Sediment prefilter installation diagram

Raw water is fed through a sediment prefilter in order to remove particles. Pressure gauges should be installed before and after the filter. If the pressure drop on the manometer is more than 0.5 bar, the sediment cartridge must be replaced. If the raw water will be treated with antiscalant or other RO chemicals, a dosing station should be installed before the filter.

3.2 Install membrane in each pressure vessel as follows.



Before installing membrane, make sure that the O-ring is assembled on the vessel end cap

3. INSTALLATION AND STARTUP

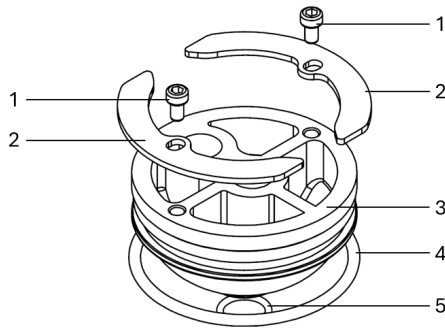

1 – screws, 2 – locking crescents, 3 – end cap, 4 – o-ring for vessel end cap, 5 – o-ring for end cap

Figure 3.2 Exploded view of pressure vessel

Disconnect poly tubes from the pressure vessel ports. Put tags or mark the disconnected tube ends to avoid confusing them later. Remove one of the end lids from each pressure vessel. First, remove the fastening bolts and take the retaining half rims out of the circular groove on the inside of the pressure vessel. Remove the lid with the membrane coupling.



Observe direction of arrow on pressure vessel when installing membrane. Use glycerol or a similar RO-compatible lubricant as needed. Avoid touching membrane with hands. Use sterile rubber gloves when handling membrane.

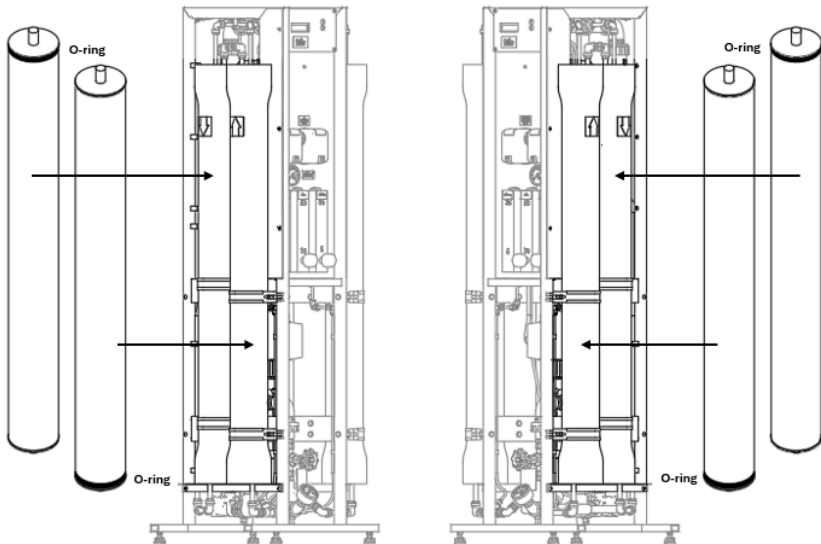

Figure 3.3 Correct position of the installed membrane

3. INSTALLATION AND STARTUP

Make a cut in membrane packaging bag and insert membrane in the pressure vessel so that the brine seal ends up in the inlet end of the pressure vessel. Central tube of the membrane must mate with membrane coupling installed at the concentrate end of pressure vessel. If necessary, remove the lid at the opposite end to facilitate installation of the membrane.

Install the lid back in place. Insert the retaining half rims back in the groove, then fasten with bolts. Re-connect the tubes in the exact way they were originally connected.

3.3 Connect the water inlet to the water mains or feed pump. Connect the drain outlet to the sewer with pipe or rigid hose. Make an air gap at the end of the drain line to prevent backsiphonage from the sewer. Connect tube or hose to permeate outlet and run it to permeate tank.

For all connections, recommended pipe size is equal or greater than that of the connection port. It is advisable to use plastic/composite pipe or rigid non-kinking hose. Use appropriate fittings as necessary.



It is strongly recommended to use short runs of pipe or hose the size of which matches or exceeds that of the connection port.

3.4 If using an atmospheric (gravity flow) pure water tank, install the float switch in the tank. Move the ballast the necessary length up the cord to ensure the proper level difference between activated and deactivated position. Then, put the float switch inside permeate tank. After the first filling of the tank, verify that the float switch activates and deactivates at the right heights.

3.5 If using service interruption by external signal (microswitch), remove conductor connecting terminals 6 and 7 together on the controller's PCB. Then, run a 2-wire cord from the external switch's normally closed pins inside the controller housing, and connect to the #6 and #7 screw terminals. If using antiscalant or other RO chemicals, refer to the dosing pump's manual for instructions regarding the dosing pump setup.

3.6 Connect the power cord to an electrical main with the necessary voltage specifications and ampacity. See the specifications section for more detail. Use a properly selected circuit breaker and a voltage stabilizer in case the electrical grid is prone to brownouts or overvoltage.

START UP THE SYSTEM AS FOLLOWS:

3.7 Make sure that the drain flow regulating valve is fully open before starting. If your unit has built-in recycle line, open the recycle regulating valve fully open as well. Make the necessary arrangements for the initial portion of permeate to be discharged to the sewer to flush out the membrane preservative.

3.8 Switch on the power supply to start the RO unit. After the controller boots up and the unit begins service, wait until the air is vented from the system and the pressure reading stabilizes. Then, tighten drain regulating valve until drain rotameter reading meets the specification (see Table 1). Then, if your unit is equipped with built-in recycle line, turn down the recycle regulating valve until the operating pressure reaches 150 ... 180 PSI, or till the recycle flow rate reaches the target value specified in the Technical Specifications. After regulating the recycle flow regulating valve, check the drain flow rate and adjust it back if it has changed.

3.9 Correctly set up flow rates ensure proper permeate recovery (product water yield): normally 20 ... 50 % for systems less recycle, up to 75 % for systems with recycle. Verify the permeate recovery after finalizing the RO unit setup using the formula:

$$\text{Recovery} = \frac{\text{Permeate flow rate}}{\text{Permeate flow rate} + \text{Drain flow rate}}$$

For example, the typical setup for an CROS less recycle would be:

Permeate flow = 5,4 gallon/minute
Drain flow rate = 1,8 gallon/minute

$$\text{Recovery} = \frac{5,4}{5,4 + 1,8} = 0,75 \text{ or } 75\%$$

3. INSTALLATION AND STARTUP

3.12 Pump throttle valve

The pump throttle valve is installed as a standard feature on BRIO reverse osmosis systems. It provides an adjustment for pump pressure. As the feed water temperature decreases, and/or the feed water TDS increases, the system will require a higher operating pressure to produce the specified permeate flow.



Please add that the valve shouldn't be closed completely as it will damage the pump!

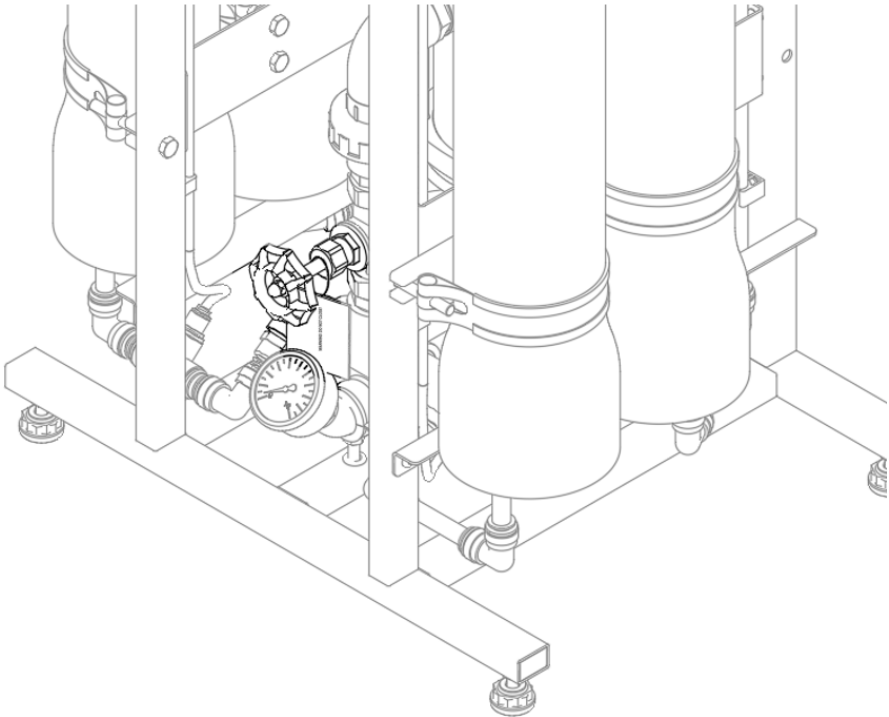

Figure 3.4 Pump throttle valve

Throttle valve is factory open. To decrease the pressure, turn the handle clockwise. To increase the pressure turn the handle counter clockwise. Pump

3. INSTALLATION AND STARTUP

3.13 Float switch

The float switch allows you to keep your water storage always topped off. When the float drops the RO turns on and produces water. When the float rises to the cut off level you have set it the RO shuts down. To install and use float switch, connect wires to float switch terminals in electrical panel. The wiring diagrams are given in Annex B. Change float switch type to NC in controller settings (Unit 8, step 1.13).

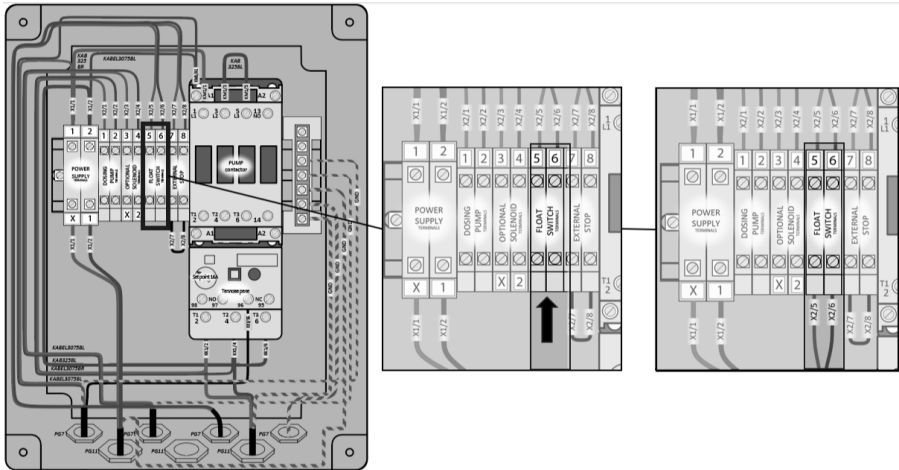

Figure 3.5 Float switch connection

*** for more information about installation contact your vendor's customer support.

4. INSTALLATION REQUIREMENTS

Installation and setup of the unit should be undertaken by a trained specialist. Room or area where the unit is to be installed must meet workplace requirements of the local building code.

- The unit must not be operated in outdoor environments. Do not expose to weather conditions (rain, temperature fluctuations, proximity of heating equipment, direct sunlight etc).
- Air at workplace should be free of corrosive vapors, airborne dust, and fibrous matter.
- To provide access to the unit for maintenance and repair purposes, respect the following clearances between the unit and building structures: 20 inches to the left or right, 8 inches above.
- Electrical connections must comply with the local electrical code. Make sure to follow applicable grounding and insulation rules.
- Supply, drain, and delivery pipework must comply with local plumbing code and have sufficient flow capacity. Drain line of the unit must be separated from floor drain with an air gap.
- Construction material or inside lining of permeate tank must be resistant to water corrosion (e. g. stainless steel, polypropylene). Tank should be installed next to the unit.
- Antiscalant pump suction line length should not exceed 60 inches.



This appliance is not intended for use by persons (including children) with reduced physical, sensory or mental capabilities, or lack of experience and knowledge, unless they have been given supervision or instruction concerning use of the appliance by a person responsible for their safety. Children should be supervised to ensure that they do not play with the appliance.

5. OPERATING REQUIREMENTS

5.1 Operator of the unit must strictly follow these guidelines and general electrical safety precautions.



This appliance is not intended for use by persons (including children) with reduced physical, sensory or mental capabilities, or lack of experience and knowledge, unless they have been given supervision or instruction concerning use of the appliance by a person responsible for their safety. Children should be supervised to ensure that they do not play with the appliance.

5.2 When operating the unit, ensure that pressure and flow rates are within specification limits and that power supply is clean and uninterrupted.

5.3 Perform the following at least once a month:

- verify that readings on pressure gauges and rotameters fall within the specified range per operating parameters specification (Table 1 and 2);
- verify tightness of hydraulic connections and integrity of parts

5.4 In order to monitor performance of the RO machine, regularly keep record of operation and write down parameter readings. Use membrane manufacturer's software tools for normalization to control for fluctuations of pressure, temperature, and other operating conditions.

5.5 Change prefilter's polypropylene cartridge when it becomes clogged. Pressure drop of 15 PSI or greater over the sediment prefilter indicates that the prefilter cartridge is clogged and must be replaced.

5.6 Perform CIP or another suitable chemical cleaning protocol when any of the following conditions are encountered:

- normalized permeate flow rate drops 10-15% of its initial value;
- normalized conductivity of permeate increases 10-15% of initial value, raw water conductivity remaining at the same level;
- normalized pressure drop over the membrane vessel increases 10-15% of its initial value. 'Normalized' parameter means a parameter measured at exactly the same operating pressure, influent water temperature, and chemical analysis as the initial measurements, against which the new measurement is compared.

5. OPERATING REQUIREMENTS

5.7 After installing freshly cleaned membrane, perform 1 hour rinse discarding all permeate and concentrate. If chemical cleaning fails to restore normalized flow or rejection rate to design specifications, membrane element is irreparably clogged and must be replaced.

5.8 To prevent microbial contamination, the unit should be operated for at least 1 hour a day. In case 48 hours or longer shutdown is to occur, membrane should be treated with preservative solution. Preservative treatment is accomplished by circulating 1% sodium metabisulfite solution through the membrane vessel for 15-30 minutes or filling the housing with metabisulfite solution of the above strength. After resuming operation of a machine that had been treated with preservative, discard all permeate obtained during the first 15-30 minutes of operation.



Do not use supply water with over 0,1 ppm of free chlorine without pre treatment with activated carbon or other means of dechlorination. Chlorine will destroy the membrane.

5.9 To replace sediment filter cartridge proceed as follows:

- remove the power from the unit;
- shut off water supply and relieve pressure;
- unscrew the filter bowl and remove it, taking care not to spill water on parts of the unit;
- remove spent cartridge from the bowl, place a clean one inside and screw the bowl back on.



Do not torque over 15 lbf × ft when tightening the filter bowl.

5.10 To replace membrane element proceed as follows:

- remove the power from the unit;
- shut off water supply and relieve pressure;
- disconnect tubes connected to the membrane vessels outlets;
- remove the top end lids with membrane couplings from the pressure vessels;
- extract used membrane from each pressure vessel;
- install new membranes; the brine seal must be in the feed end of each vessel;
- install the end lids with membrane couplings back in their seats;
- re-connect tubes back to the end lids.



Do not torque over 15 lbf × ft when tightening the filter bowl.



Do not subject pressure vessel to mechanical impact (shocks, static load etc).



The manufacturer shall not be held liable for any damages incurred by the owner of the unit or any third party due to failure to adhere to the safety precautions or installation guidelines herein.

6. SHIPPING AND STORAGE REQUIREMENTS

- The unit must be stored indoors. Ambient air quality must meet workplace standards.
- Carry out preservative treatment of the membranes before prolonged shutdown.
- The product in its original packaging can be shipped by all types of air, sea or ground transport.
- During transportation, the product must be protected from exposure to low temperatures and jolts or strong vibration.

7. TROUBLESHOOTING



Do not access any electrical parts before ensuring that the electrical power has been removed.
Do not access any electrical parts or attempt any diagnostics / repair unless you are a trained electrician.

PROBLEM	POSSIBLE CAUSE	CORRECTIVE ACTION
The controller is not starting after powering up the unit	No power / incompatible power supply	Ensure that the power meets Technical specifications . If the power supply is adequate, then switch off the power first , open the controller housing and check: <ul style="list-style-type: none"> the fuses are not blown wires in screw terminals #30, #31, #32 are not loose
Circuit breaker trips in the main panel	Power supply does not meet system requirements	The system requires clean power supply compliant with the Technical specifications. Check for brownout, overvoltage, power surges.
The pump will not start after the controller boots up	Controller is in Standby mode	Check if the permeate tank is full, or if the float switch has stuck in the upward position. Check that the permeate pipeline is not blocked or shut off with a valve.
	Controller is in Stop mode	Push START button to see if it is manually stopped. If nothing happens, then (remove the power first!) open the controller housing and check that terminals #6 and #7 on the PCB are connected with a jumper wire.
	Controller is in Service mode but the pump isn't running	Thermal overload relay (in the electrical panel with the 230 V label sticker) may trip due to pump stalling, jamming, or inadequate voltage. Another possibility is a loose wire in the controller terminal block or in the electrical panel (remove power before accessing the electrical parts!)
Low feed pressure fault occurs immediately after startup	The air has not been completely purged from the system	Fill the system completely with water. One way to do this is to enter controller settings and temporarily set 1.1 High pressure pump delay to 255 seconds, then revert back after the air bubbles disappear.
	Obstruction in the water supply pipeline	Avoid using long runs of small diameter pipes. Check that there are no sharp bends if using a flexible hose.
	Clogged prefilter	Check the filter cartridge and replace if necessary.
Low feed pressure fault occurs after running smoothly for a while	Insufficient water supply capacity leading to a sharp pressure drop during Forward Flush cycle	The system requires a higher supply water flow rate for the duration of the Forward flush cycle. If the problem can't be resolved, it can be bypassed by entering the Controller Settings and changing 1.7 Read low feed pressure during Forward Flush to off (Warning: this will lead to less efficient membrane rinse so quicker membrane deterioration)

7. TROUBLESHOOTING

	Clogged pre-filter cartridge or water supply pressure dip	Check the filter cartridge and replace if necessary. Check that the influent pressure is stable.
High permeate conductivity	High water temperature	Check that the feed water temperature meets the provisions of Technical specifications .
	Operating pressure and/or concentrate flow rate is too low	Check that the flow rates and the operating pressure meet the provisions of Technical specifications .
	Poor quality influent water	Verify that the water analysis meets the requirements of the Technical specifications .
	Damaged seal on the membrane or membrane coupling connector	Replace the damaged seals.
	Membrane fouling, scaling, or mechanical damage	Replace the membrane or carry out chemical cleaning
Low permeate flow rate	Low water temperature	Check that the feed water temperature meets the provisions of Technical specifications
	Operating pressure and/or concentrate flow rate is too low	Check that the flow rates and the operating pressure meet the provisions of Technical specifications
	Membrane fouling or scaling	Replace the membrane or carry out chemical cleaning
Other	Other issue / unclear possible cause	Contact your vendor's customer support

8. CONTROLLER

8.1. OVERVIEW

Brio OC5000 process controller is used for automating reverse osmosis system operation. The input and output device connections are described in the table below.

Depending on current status and input device readings the controller will operate in any of the following modes: Service, Standby, Forward Flush, Stop, Fault (described in the following section).

The user interface comprises two buttons and an LCD display. ■ STOP button is used for stopping the unit (short press) or entering the **Settings** menu (long hold). ► START button is used for scrolling in the Settings menu or initiating a Forward Flush (if pressed during service screen display).

8.2. INPUT & OUTPUT SPECIFICATIONS

Table 4 . List of terminals

PURPOSE	VOLTAGE	MARKING	PIN #
Power supply			
Live	110-220 VAC,	L	32
Neutral	50/60 Hz	N	31
Ground	Ground	⏚	30
Input terminals			
Conductivity meter		Cond	1 – white 2 – black
Temperature sensor		+ Term –	3 – red 4 – green 5 – blue
Low feed pressure switch	5 V (only use dry contact NC/NO switches)	P_in	8–9
High operating pressure switch		P_max	10 – 11
High permeate pressure switch		P_perm	12 – 13
Permeate float switch		Level	14 – 15
Stop switch		Stop	6 – 7
Output terminals			
Pump contactor	110-220 VAC (matching the power supply voltage)	PUMP	28 – 29 27 (ground)
Alarm signal out		ALARM	25 – 26
Entry electric valve		Valve_IN	24 (neutral) 23 (open) 22 (ground)
Flush electric valve		Valve_Rinse	21 (neutral) 20 (open) 19 (ground)
Bypass electric valve		Valve_Bypass	18 (neutral) 17 (open) 16 (ground)

For more detail, please see the wiring diagram, given in **Annex B**.

8. CONTROLLER

8.3. OPERATING MODES

When operating, the controller will be in any one of the following modes: Service, Stop, Forward Flush 1, Forward Flush 2, Standby, Fault. Immediately after starting, the controller will display firmware version and then proceed to Service if tank permeate level is low and backpressure switch is not activated.

Here and below information is relevant to the firmware version "OC5000EC ver_03". For information on different firmware versions please contact your technical support.

Configuring and manipulating the controller is done using ► START and ■ STOP buttons. Current mode of operation and pertaining information is shown on the LED display. Opening the circuit in the Stop domain of terminal block (see figure 1) will bring the controller to Stop mode regardless of its current mode of operation. Closing the circuit will take the controller back to the mode that had been interrupted. Stop terminals can be used to connect a microswitch on pre-treatment media filter, a relay or other means of external control to the controller.

Following is the description of controller modes.

SERVICE.

In Service mode, the RO machine produces permeate. If no fault conditions are taking place, float switch is low and backpressure switch is not activated, the controller will operate in Service mode.

Status of outputs in SERVICE	
Booster and antiscalant pumps	on
Entry valve	open
Forward flush valve	closed (not available in this system)
Bypass valve	open (if configuration step 1.3 is set to 0) closed (if configuration step 1.3 is non-zero value)
Alarm	off

Display will flash cumulative runtime of the RO machine, remaining time before scheduled maintenance alert (if set in configuration step 3.1), temperature and conductivity of permeate (or TDS of permeate if configuration step 1.15 is set to "on"). Pushing ► START once will initiate Forward Flush 1, pushing ► START twice in 0.5 seconds or less will initiate Forward Flush 2 (if configuration step 1.3 is set to non-zero value), pushing ■ STOP will bring on Stop mode. If high feed pressure, low feed pressure, or high permeate conductivity condition occurs, the controller will go into Fault mode.

FORWARD FLUSH 1

This mode is not provided in the current system.

FORWARD FLUSH 2

This mode is not provided in the current system.

STANDBY

In Standby, the unit is stalled and ready to resume service. Standby mode is brought on by reading high tank level or tripping permeate backpressure switch.

8. CONTROLLER

Status of outputs in STANDBY	
Booster and antiscalant pumps	off
Entry valve	closed
Forward flush valve	closed (not available in this system)
Bypass valve	closed
Alarm	off

Pushing ■ STOP will bring the controller to Stop mode. Pushing ► START will take the controller into Service if permeate is low and backpressure switch is inactive. Otherwise, pushing ► START will initiate Forward Flush 1 and Forward Flush 2 (if set) and then bring the controller back to Standby. When float switch or permeate backpressure switch deactivate, the controller will go back to Service.

FAULT

In Fault mode, the unit is stalled to protect the equipment from dangerous operating conditions. Fault mode is brought on by activating low feed pressure switch (to prevent 'dry running'), high feed pressure switch (to protect against overpressure), or reading an excessively high permeate conductivity value (which could mean membrane rupture or other malfunction if configuration step 1.16 is set to non-zero value.).

Status of outputs in FAULT	
Booster and antiscalant pumps	off
Entry valve	closed
Forward flush valve	closed (not available in this system)
Bypass valve	closed
Alarm	off

Fault mode can only be quit manually by pushing ► START. Ensure the cause of fault is eliminated before quitting Fault mode. Pushing ■ STOP will bring the controller to Stop mode.

STOP

In Stop mode, the unit is stalled and awaiting further input. Stop mode can be manually brought on by pushing ■ STOP in any mode, or by stop switch opening circuit between STOP terminals on the printed circuit board.

Status of outputs in FAULT	
Booster and antiscalant pumps	off
Entry valve	closed
Forward flush valve	closed (not available in this system)
Bypass valve	closed
Alarm	off

Upon pushing ► START or deactivating stop switch, the controller will resume from where it was interrupted.

8. CONTROLLER

8.4. PROGRAM SETTINGS

MENU	FACTORY SETTINGS
SETTINGS	
1. SETTINGS AND CALIBRATION PASSCODE PROMPT	0000
1.0 Language	English
1.1 High pressure pump delay, s	10 s*
1.2 Forward Flush 1 duration, s	0 s
1.3 Forward Flush 2 duration, s	0 s
1.4 High pressure pump power during Forward Flush 2, on/off	off
1.5 Frequency of periodic Forward Flush in Service, h	0 s
1.6 Frequency of periodic Forward Flush in Standby, h	0 s
1.7 Read low feed pressure during Forward Flush, on/off	on
1.8 Low feed pressure switch, NO/NC	NO
1.9 Low feed pressure Fault delay, s	3 s
1.10 High feed pressure switch, NO/NC	NO
1.11 Permeate backpressure switch, NO/NC	NC
1.12 Backpressure Standby delay, s	1 s
1.13 Tank level switch, NO/NC	NO
1.14 Tank level Standby delay, s	1 s
1.15 Display TDS in ppm	on
1.16 Permeate conductivity Fault threshold, $\mu\text{S}/\text{cm}$	0 $\mu\text{S}/\text{cm}$
1.17 Permeate conductivity Fault delay, s	0
1.18 Display temperature	F
1.19 New settings and calibration passcode	–
2. SETTINGS AND CALIBRATION PASSCODE PROMPT	0000
2.1 First point value, $\mu\text{S}/\text{cm}$	–
2.2 Second point value, $\mu\text{S}/\text{cm}$	–
3. MAINTENANCE PASSCODE PROMPT	0000
3.1 Schedule maintenance stop, on/off	off
3.2 Scheduled stop period, h (if 3.1 is set to 'on')	500 hour
3.3 New maintenance passcode	

*Before first start of the system change the high pressure pump delay at 255 sec to release the air from the unit. After successfully running the RO unit, revert back to the factory setting of 10 sec.

8. CONTROLLER

1. SETTINGS

Hold ■ STOP for 8 seconds to launch menu prompt. Push ► START to enter Settings submenu. Enter passcode in the prompt. Factory passcode is '0000'.

1.0 Language

Choose language to display operation information & menu. Available languages include English.

1.1 High pressure pump delay

Enter length of interval between opening the entry valve and starting the pump when the unit is going into Service (0...255 seconds). **(10 seconds)**

1.2 Forward Flush 1 duration

Enter length of Forward Flush 1 (0...255 seconds). Forward Flush 1 will not be performed if the parameter is set to zero. **(0 seconds - This mode is NOT available in the system)**

1.3 Forward Flush 2 duration.

Enter length of Forward Flush 2 (0...255 seconds). Forward Flush 2 will not be performed if the parameter is set to zero. **(0 seconds - This mode is NOT available in the system)**

1.4 High pressure pump power during Forward Flush 2.

This setting specifies whether the high pressure pump will be powered during Forward Flush 2. **(off)**

1.5 Frequency of periodic Forward Flush in Service.

This setting determines how often Service mode is interrupted to run forward flush sequence (once in 0...255 hours). **(0 hours)**

1.6 Frequency of periodic Forward Flush in Standby.

This setting determines how often Standby mode is interrupted to run forward flush sequence (once in 0...255 hours). **(0 hours)**

1.7 Read low feed pressure during Forward Flush.

This setting specifies if low feed pressure switch status will be read by the controller during forward flush. If set to 'off', low feed pressure situation will not bring about Fault mode. **(on)**

1.8 Low feed pressure switch.

This setting specifies whether low feed pressure switch is normally closed (NC) or normally open (NO) type. **((NO) type)**

1.9 Low feed pressure Fault delay.

Specify the length of time before the controller goes into Fault mode if low feed pressure condition occurs (0...255 seconds). The pump will continue to run for this many seconds before Fault mode is switched to. If set to 0, pump will stop running immediately after low feed pressure occurs. **(3 seconds)**

1.10 High feed pressure switch.

This setting specifies if high feed pressure switch is normally closed (NC) or normally open (NO) type. **((NO) type)**

1.11 Permeate backpressure switch.

This setting specifies whether backpressure switch is normally closed (NC) or normally open (NO) type. **((NC) type)**

8. CONTROLLER

1.12 Backpressure Standby delay.

Specify the length of time before the controller goes into Standby if high permeate pressure condition occurs (0...255 seconds). Controller will continue to operate in Service mode for the set length of time before running pre-Standby forward flush or will initiate Forward flush immediately if value set to 0. **(1 second)**

1.13 Tank level switch.

This setting specifies whether float switch is normally closed (NC) or normally open (NO) type. **((NO) type** - this equipment NOT available in this system, but can be added, see UNIT 3, step 3.13)

1.14 Tank level Standby delay.

Specify the length of time before the controller goes into Standby if tank level switch goes high (0...255 seconds). Controller will continue to operate in Service mode for the set length of time before running pre-Standby forward flush or will initiate Forward flush immediately if value set to 0. **(1 second)**

1.15 Display permeate TDS in ppm.

If set to "on", electrical conductivity (EC) of permeate will be displayed as TDS in ppm as $TDS = 0.5147 * EC$. **(on)**

1.16 Permeate conductivity Fault threshold.

Specify maximum acceptable permeate conductivity. Conductivity reading above this value will initiate Fault mode ('High permeate TDS'). If set to zero, fault threshold will not be used.

1.17 Permeate conductivity Fault delay.

Specify the length of time before the controller goes into Fault mode when high permeate conductivity is being read. Step 1.17 is displayed only if step 1.16 is set to non-zero value. **(0 second)**

1.18 Display temperature.

Select units of temperature (C for Celsius, F for Fahrenheit).

1.19 New settings and calibration passcode.

Verify passcode.

2. CALIBRATION

2.1 Electrical conductivity probe calibration

Hold **■ STOP** for 8 seconds to launch menu prompt. Push **■ STOP** to skip Settings submenu and push **▶ START** to enter Calibration submenu. Enter passcode in the prompt. Factory passcode is '0000'.

First point value

First calibration point can be done at zero electrical conductivity (dry conductivity meter). In order to use zero first point conductivity, remove the conductivity meter from its cell, wipe with clean cloth and keep dry for a few minutes. When conductivity reading on the display stabilizes, put zeroes in the bottom row, and go to the next step. If using a weakly conducting solution to set the first point, rinse the meter with deionized water and wipe dry. Dip clean conductivity meter into sample of known standard conductivity, wait until the reading on display stabilizes and input actual conductivity. Then go to the next step.

Second point value

Use water sample with greater conductivity than that of the first point standard. Follow the same procedure rinsing and wiping residual moisture on conductivity meter electrodes. Dip clean conductivity meter into sample of known standard conductivity, wait until the reading on display stabilizes and input actual conductivity. Then go to the next step. The controller will display 'OK' and show Maintenance submenu prompt.

8. CONTROLLER

2.2 Low feed pressure switch calibration

Low pressure switch has adjustable nut, which can be adjusted with a wrench. This function is done by changing the amount of compression in range large center spring. If the large range spring is more compressed by screw, the set point of pressure switch will be high. If you adjust the range to high value, the pump will not shut off. If this happens, loosen the nut until the pump can successfully reach the new cut of pressure and turn off.

Low feed pressure switch is factory calibrated for 15 psi.

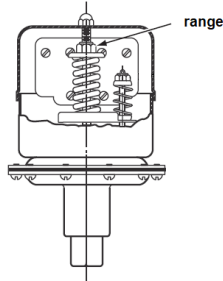

Figure 8.1 Low feed pressure switch

2.3 Permeate backpressure switch calibration

Permeate backpressure switch has adjustable nut, which can be adjusted with a wrench. This function is done by changing the amount of compression in range spring. If the range spring is more compressed by screw, the set point of pressure switch will be high. If you adjust the range to high value, the pump will not shut off. If this happens, loosen the nut until the pump can successfully reach the new cut of pressure and turn off.

Permeate backpressure switch is factory calibrated for 45 psi.

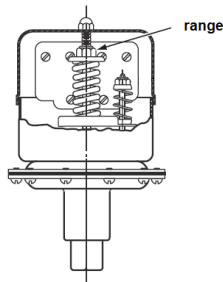

Figure 8.2 Permeate backpressure switch

3. MAINTENANCE

Maintenance submenu will be shown after completing calibration of conductivity meter and can be called up during Service by holding ■ STOP for 8 seconds, then skipping Settings and Calibration prompt displays. Enter Maintenance passcode in the prompt. Factory passcode is '0000'.

8. CONTROLLER

3.1 Schedule maintenance stop

Select 'on' to turn on maintenance reminder after preset number of hours of cumulative runtime. Controller will put the RO machine to a halt and display maintenance alert message. Operation can only be continued after entering Maintenance submenu (with proper Maintenance passcode) and resetting scheduled stop period. If set to 'off', the controller will continue to count overdue hours after reaching zero hour count.

3.2 Scheduled stop period

Enter the number of hours before the RO machine will be brought to a scheduled stop for maintenance. This setting will not be shown if the scheduled stop is turned off in step 3.1.

3.3 New Maintenance passcode

Enter new passcode for Maintenance submenu and confirm. This will exit the Configuration menu.

ANNEX A

TECHNOLOGICAL SCHEME

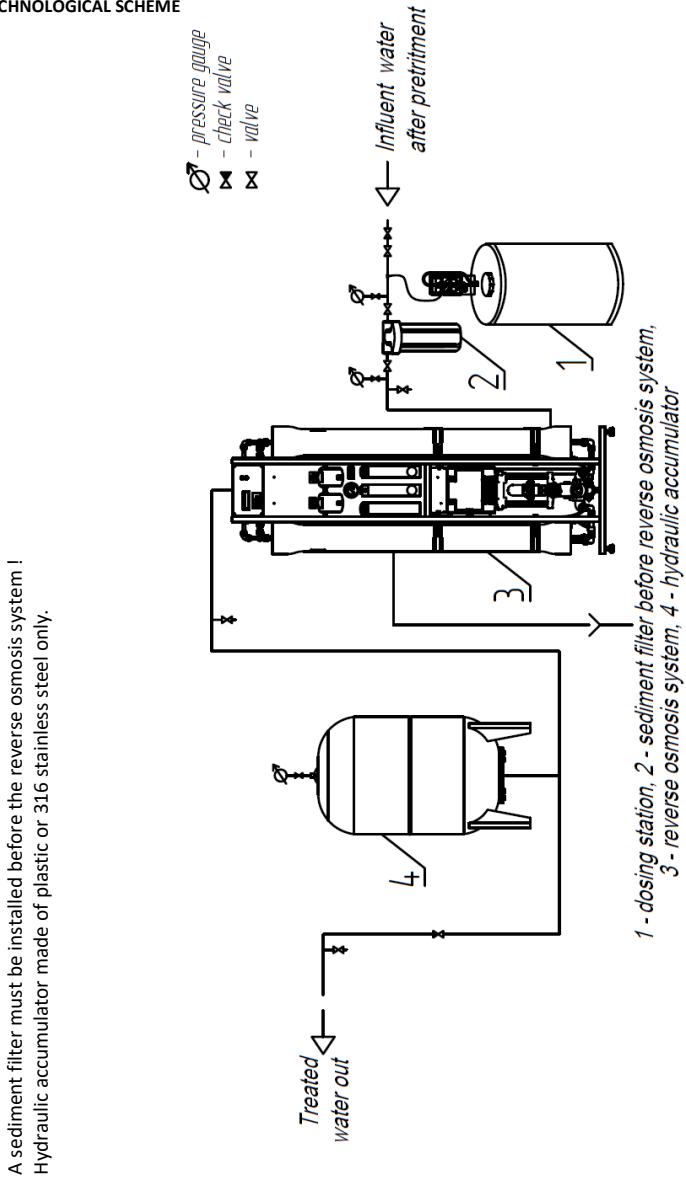
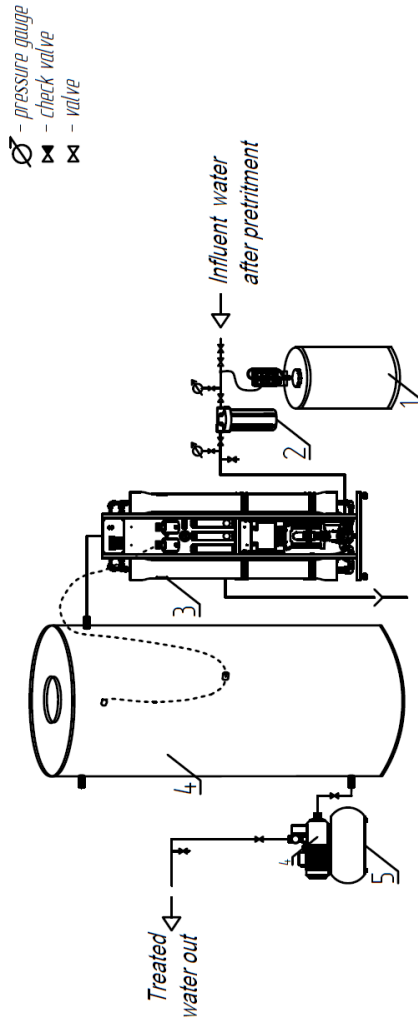

Figure A1 Standard technological scheme included dosing station

ANNEX A

TECHNOLOGICAL SCHEME

A sediment filter must be installed before the reverse osmosis system !
 Float switch not included in CROS4591 system.



- 1 - dosing station, 2 - sediment filter before reverse osmosis system,
- 3 - reverse osmosis system, 4 - storage tank, 5 - high pressure pump

Figure A2 Standard technological scheme included dosing station

ANNEX A

TECHNOLOGICAL SCHEME

A sediment filter must be installed before the reverse osmosis system !
 Hydraulic accumulator made of plastic or 316 stainless steel only.

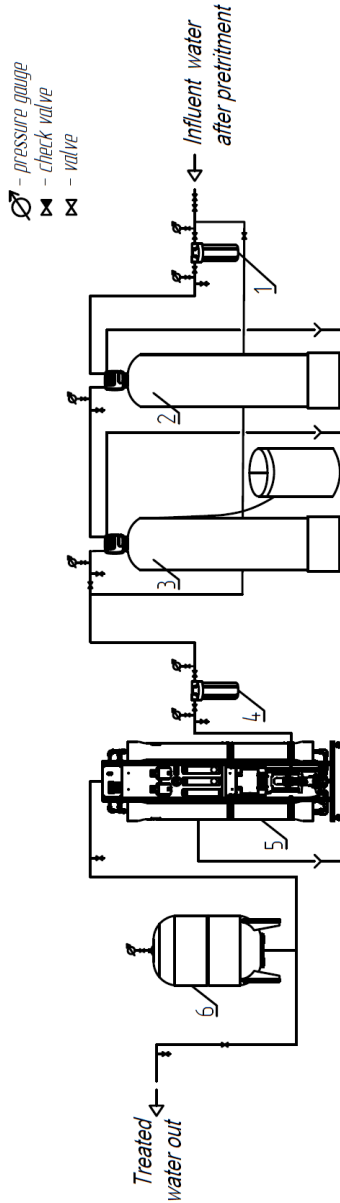

- 1 - sediment filter, 2 - carbon or multimedia filter, 3 - softener,
- 4 - sediment filter before reverse osmosis system, 5 - reverse osmosis system, 6 - hydraulic accumulator

Figure A3 Standard technological scheme

ANNEX A

TECHNOLOGICAL SCHEME

A sediment filter must be installed before the reverse osmosis system !
 Float switch not included in CROS44591 system.

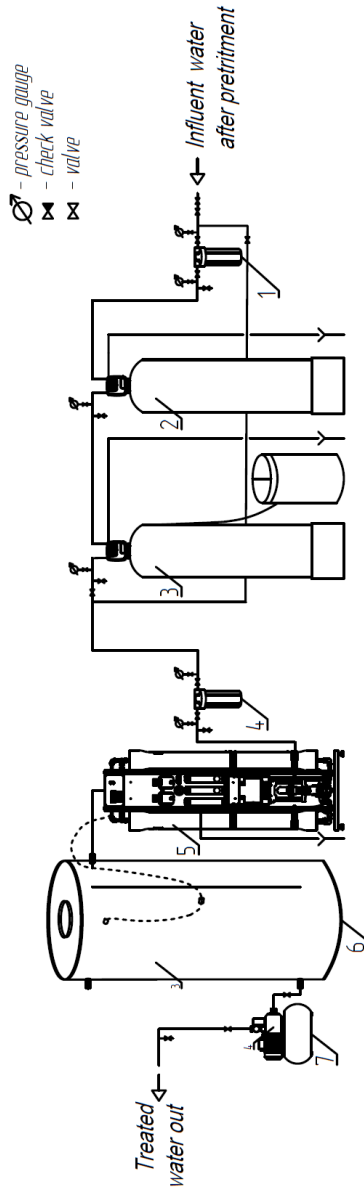

1 - sediment filter, 2 - carbon or multimedia filter, 3 - softener,
 4 - sediment filter before reverse osmosis system, 5 - reverse osmosis system, 6 - storage tank, 7 - high pressure pump

Figure A4 Standard technological scheme

ANNEX B

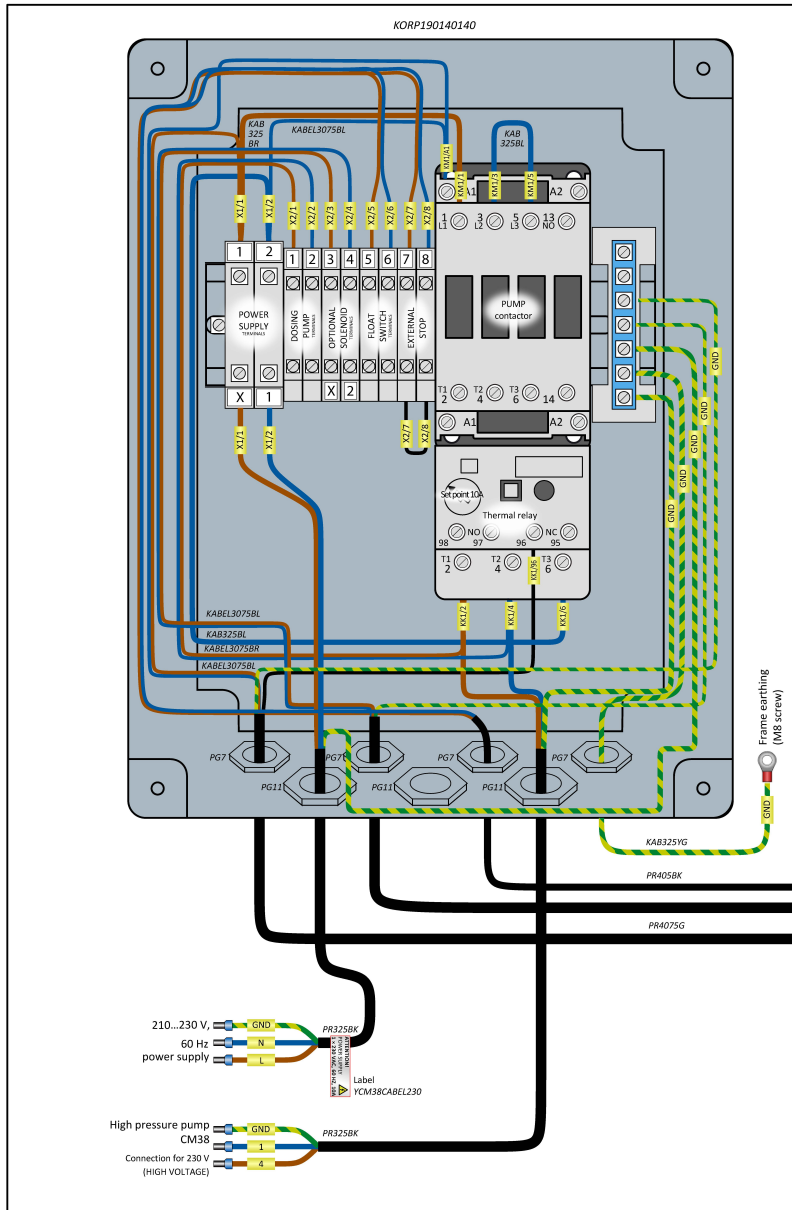

ANNEX B

BRIO
CROS4591
REVERSE OSMOSIS SYSTEM WIRING DIAGRAM

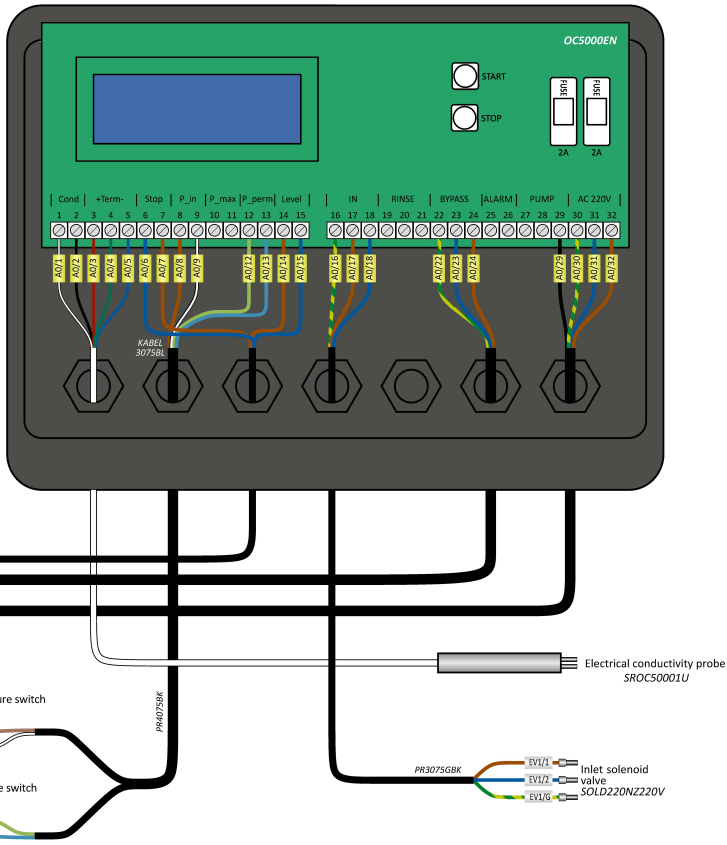

ANNEX C

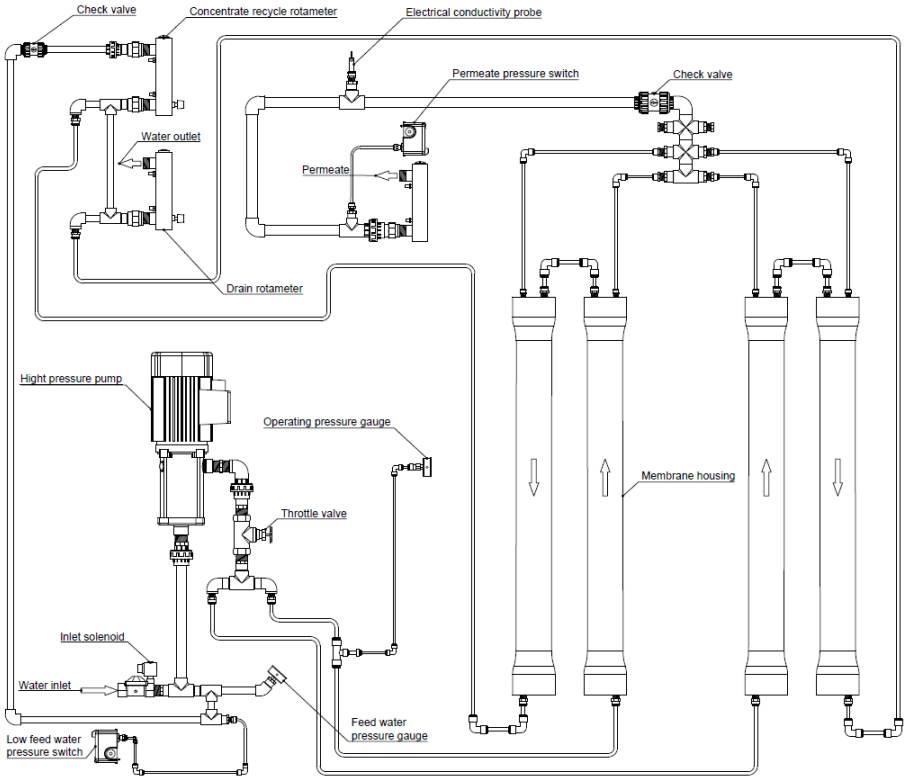

Figure B1 Layout of CROS4591 6x4-inch membrane commercial RO system

9. WARRANTY

Brio ("Vendor") warrants to the original purchaser of the Brio Water Filters (the "Product"), and qto no other person, that if the Product is assembled and operated in accordance with the printed instructions accompanying it, then for a period of one (1) year from the date of purchase, all parts in the Product shall be free from defects in material and workmanship. This Limited Warranty shall be limited to repair or replacement of parts, which prove defective under normal use and service and which Vendor shall determine in its reasonable discretion upon examination to be defective. To take advantage of this Limited Warranty, please follow these steps:

1. Please retain your sales slip or invoice, as Vendor may require reasonable proof of your date of purchase.
2. Contact Vendor's Customer Service Department using the contact information listed below.
3. Return parts to Vendor, per Vendor's instructions, at your cost and expense.
4. Upon receipt by Vendor, Vendor shall advise you in writing whether a defect covered by this Limited Warranty exists in any returned part and whether your claim has been approved or denied.
5. Upon Vendor's approval of your claim, Vendor will replace such defective part without charge to you.

WHAT THIS LIMITED WARRANTY DOES NOT COVER: This Limited Warranty does not cover any fail- ures or operating difficulties of the Product due to accident, abuse, misuse, alteration, misapplica- tion, improper installation or improper maintenance or service by you or any third party, or failure to perform normal and routine maintenance on the Product, as set out in the User's Manual. In addition, this Limited Warranty does not cover damages to the finish, such as scratches, dents, dis- coloration or rust after purchase. This Limited Warranty is the only express warranty given on the Product and is in lieu of all other express warranties. Vendor disclaims all warranties for products that are purchased from seller other than authorized retailers or distributors.

THIS LIMITED WARRANTY RESTRICTS THE DURATION OF ANY AND ALL IMPLIED WARRANTIES, IN- CLUDING WITHOUT LIMITATION, THE IMPIED WARRANTY OF MERCHANTABILITY AND FITNESS FOR A PARTICULAR PURPOSE TO THE ONE (1) YEAR TERM OF THIS LIMITED WARRANTY. UPON THE EX- PIRATION OF THE ONE (1) YEAR TERM OF THIS LIMITED WARRANTY, VENDOR DISCLAIMS ANY AND ALL IMPLIED WARRANTIES, INCLUDING WITHOUT LIMITATION THE IMPLIED WARRANTIES OF MER- CHANTABILITY AND FITNESS FOR A PARTICULAR PURPOSE, THE PRODUCT BEING THUS SOLD AS- IS, WITH ALL FAULTS. FURTHER, VENDOR SHALL HAVE NO LIABILITY WHATSOEVER TO PURCHASER OR ANY THIRD PARTY FOR ANY SPECIAL, INDIRECT, PUNITIVE, INCIDENTAL, OR CONSEQUENTIAL DAMAGES. OTHER THAN THIS LIMITED WARRANTY, THERE ARE NO WARRANTIES WHICH EXTEND

BEYOND THE DESCRIPTION ON THE FACE HEREOF. Vendor assumes no responsibility for any defects caused by third parties. This Limited Warranty gives you specific legal rights, and you may have other rights which vary from state to state. State law may also override statements in this Limited Warranty regarding the restriction on the duration of implied warranties. Some jurisdictions do not allow exclusion or limitation of special, incidental or consequential damages, or limitations on how long a warranty lasts, so the above exclusion and limitations may not apply to you.

WARRANTY REGISTRATION CARD

**ONLY THE ORIGINAL WARRANTY REGISTRATION CARD
WITH SIGNATURE AND STAMP OF THE DEALER IS VALID**

Product: **WATER PURIFICATION SYSTEM**

Model: _____

Code: _____

Serial №: _____

Date of manufacture: _____

Guaranteed service life: **12 months from the date of sale**

date of sale

dealer company

seller (name and signature)

